

# SSC-G218

Analog Color Fixed Cameras

**SONY**  
make.believe

## 650 TV Line Security Camera with High Sensitivity

- Horizontal resolution of 650 TV lines
- High sensitivity  
Color: 0.15 lx (F1.2, 50 IRE, AGC ON)  
B/W: 0.01 lx (F1.2, 50 IRE, AGC ON)
- CS mount lens\*
- Compact design

\* A lens is an optional.



### KEY FEATURES

- High resolution (650 horizontal TV lines) and high sensitivity (Color : 0.15 lx / B/W : 0.01 lx, F1.2, 50 IRE) achieved by an 1/3-type "EXview HAD CCD II" sensor and Sony's new digital signal processor, "Effio-E"

#### **EXview HAD CCD II™**

- Optical Day / Night function to switch to Day or Night mode depending on the light level
- Low power consumption: 2.0 W (Max.)
- Dip SW Control for easy mode setting
- ATR-Lite (Adaptive Tone Reproduction Lite) to compensate for gradation of subjects to an optimum level
- iBLC to compensate for exposure levels in dark scenes to improve subject visibility
- ATW (Automatic Tracing White) balance which automatically adjusts the camera's white balance to adapt to sudden changes in lighting conditions
- Internal lock, and line lock selectable
- 2D noise reduction employed
- AC 220 V - 240 V operation

## SPECIFICATIONS

| SSC-G218                           |   |
|------------------------------------|---|
| <b>Camera</b>                      |   |
| Image device                       | 1/3-type "EXview HAD CCD II"  |
| Number of effective pixels (H x V) | 570,000 pixels (976 x 582)  |
| Signal system                      | PAL standard  |
| Horizontal resolution              | 650 TV lines  |
| S/N ratio                          | More than 55 dB (AGC Off)   |
| Minimum illumination               | Color: 0.15 lx, B/W: 0.01 lx (F1.2, 50 IRE)<br>Color: 0.08 lx, B/W: 0.003 lx (F1.2, 30 IRE) |
| Video output                       | VBS:1.0 Vp-p  |
| Synchronization                    | Internal/AC line lock selectable  |
| Gain control                       | Auto (on/off)   |
| White balance                      | ATW (2000K to 10000K), ATW-PRO (2500K to 6000K)   |
| Lens type                          | CS mount lens*  |
| <b>Camera Features</b>             |   |
| Day/Night                          | Yes   |
| Noise reduction                    | Yes (2D NR)   |
| Back light compensation            | Yes (iBLC)  |
| Automatic tone reproduction        | Yes (ATR-Lite)  |
| <b>General</b>                     |   |
| Mass                               | 260 g (9.2 oz)  |
| Dimensions                         | 117.6 x 63.2 x 57.2 mm<br>(4 3/4 x 2 1/2 x 2 3/8 inches)                                    |
| Power requirement                  | AC 220 V to AC 240 V  |
| Power consumption                  | 2.0 W   |
| Operating temperature              | -10 °C to +50 °C (14 °F to 122 °F)  |
| Storage temperature                | -40 °C to +60 °C (-40 °F to +140 °F)  |
| Operating humidity                 | 20% to 80%  |
| Storage humidity                   | 20% to 95%  |
| Supplied accessories               | Operating instructions x1, Lens mount cap x1, Power cable x1                                |

\* A lens is an optional.

## DIMENSIONS

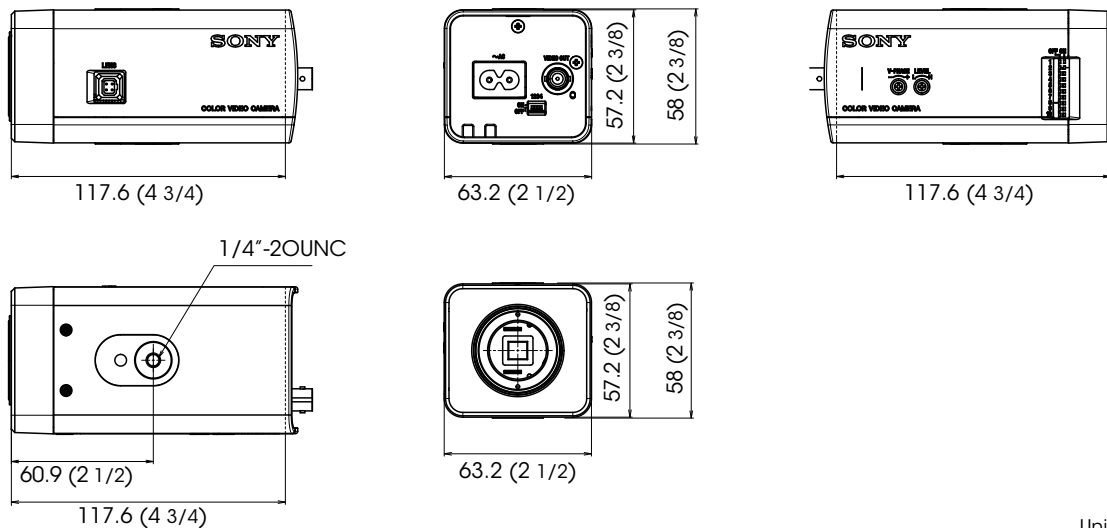

Unit: mm (inches)

Distributed by

© 2012 Sony Corporation. All rights reserved.  
 Reproduction in whole or in part without written permission is prohibited.  
 Features and specifications are subject to change without notice.  
 The values for weight and dimension are approximate.  
 "SONY", "make.believe", "Effio-E", and "EXview HAD CCD II" are  
 trademarks of Sony Corporation.  
 All other trademarks are the property of their respective owners.