

HD ENG Broadcast and Professional lenses for Sony HD 1/2"



This HD ENG line-up has been developed to meet the demand for additional lenses for the Sony 1/2" 3CCD HD camcorders, i.e. offering more wide angle or more zoom paired with the renowned Fujinon image quality and reliability.

The complete range of the 1/2" 3CCD HD lens category includes models which are true broadcast lens designs, meeting the highest demands for top-notch image quality and Digi Power functionality. To complete the choice of lenses in this field Fujinon also offers the XS20x6.3B professional HD lens, in order to meet the demand for an entry level HD lens with a surprisingly high quality!

► HD ENG Broadcast lenses

This lens range consisting of XS13x3.3B, HS16x4.6BE, XS17x5.5B, ZS17x5.5BE, HSs18x5.5B and HS18x5.5BE share the same general design as the renowned Fujinon 2/3" HA Premier Broadcast lenses, and offer you a choice of a super wide lens such as the XS13x3.3B, all-round lenses (HS16x4.6BE) and a selection of standard zoom lenses with and without extender! These lenses have been designed using Fujinon's exclusive GO-Technology which ensures the highest optical quality, delivering excellent MTF values overall. These lenses also feature Fujinon's Digital Power Broadcast drive units, offering functions such as QuickZoom, Zoom Mode Select, Auto-cruising Zoom and Zoom Maximum Speed Adjustment.

This range of lenses gives you the choice to select a standard lens with or without extender, depending on your needs and budget volume.

With these lenses Fujinon offers powerful tools for HD XDCAM users for any job, from close-up situations in confined conditions to framing distant objects.

► Professional HD ENG lens

The XS20x6.3B lens is a very cost-efficient and therefore popular HD Professional ENG style 1/2" telephoto lens. With the attractive 20x zoom factor, which is renowned for having good value at an affordable price, it also features overall enhanced quality, plus a fast, quiet and precise servo zoom.

Its ergonomic professional Digi Power servo drive unit comes with QuickZoom and the lens has been designed using the newest EBC glass surface coating (Electron Beam Coating), which considerably improves light transmission. The XS20x6.3B lens features a focal length from 6.3mm to 126mm with a maximum relative aperture of F1.4 at 6.3mm to F2.0 at 126mm. For additional ease of use it has also been fitted with an ergonomically designed professional handgrip offering all the easy-to-use and comfortable functions needed for your successful shootings, such as a maximum zoom speed of only one second!

The XS20x6.3B lens is best suited for demanding professional video productions!

Fujinon. To see more is to know more.

- ▶ HS16x4.6BERM
HS16x4.6BERD
Broadcast lens



Specifications/Lens	HS16x4.6BERM / HS16x4.6BERD
Zoom ratio / Format	16x / 1/2"
Focal length	(1x) 4.6–74 mm / (2x) 9.2–148 mm
Maximum relative aperture	F1.4 (4.6–47 mm) / F2.2 (74 mm)
Angular field of view 16:9 Aspect ratio	4.6 mm: 74°18'x46°09' / 74 mm: 5°24'x3°02'
M.O.D. (Minimum Object Distance) from front of lens	0.40 m
Object dimensions at M.O.D.	4.6 mm: 710 x 399 mm / 74 mm: 44 x 25 mm
Filter size	ø 107 mm P=1
Dia ø x Length (w/o hood)	ø 95 x 240 mm
Weight (w/o hood)	1.98 kg
Options	16-bit encoder
Features ²	IF QZ ZL *
Remote set system for -RM lenses / manual Focus	MS-11D, SS-11D, MS-11, SS-11, MM-11
Remote set system for -RD lenses / servo Focus	SS-13D, SS-14S, SS-13A

- ▶ HSs18x5.5BRM
HSs18x5.5BRD
HS18x5.5BERM
HS18x5.5BERD
Broadcast lens



Specifications/Lens	HSs18x5.5BRM / HSs18x5.5BRD HS18x5.5BERM / HS18x5.5BERD
Zoom ratio / Format	18x / 1/2"
Focal length	(1x) 5.5–100 mm / (2x) 11–200 mm**
Maximum relative aperture	F1.4 (5.5–78 mm) / F1.8 (100 mm)
Angular field of view 16:9 Aspect ratio	5.5 mm: 64°43'x39°14' / 100 mm: 4°00'x2°15'
M.O.D. (Minimum Object Distance) from front of lens	0.60 m
Object dimensions at M.O.D.	5.5 mm: 741 x 417 mm / 100 mm: 41 x 23 mm
Filter size	ø 85 mm P=0.75
Dia ø x Length (w/o hood)	ø 85 x 206.6 mm
Weight (w/o hood)	1.58 kg / 1.6 kg
Options	16-bit encoder
Features ²	IF QZ ZL *
Remote set system for -RM lenses / manual Focus	MS-11D, SS-11D, MS-11, SS-11, MM-11
Remote set system for -RD lenses / servo Focus	SS-13D, SS-14S, SS-13A

- ▶ XS13x3.3BRM
Broadcast lens



Specifications/Lens	XS13x3.3BRM
Zoom ratio / Format	13x / 1/2"
Focal length	3.3–43 mm
Maximum relative aperture	F1.4 (3.3–32 mm) / F1.9 (43 mm)
Angular field of view 16:9 Aspect ratio	3.3 mm: 93°07'x61°25' / 43 mm: 9°16'x5°13'
M.O.D. (Minimum Object Distance) from front of lens	0.30 m
Object dimensions at M.O.D.	3.3 mm: 752 x 406 mm / 43 mm: 58 x 31 mm
Filter size	ø 127 mm P=0.75
Dia ø x Length (w/o hood)	ø 95 x 240.5 mm
Weight (w/o hood)	1.93 kg
Options	16-bit encoder
Features ²	IF QZ ZL *
Remote set system for -RM lenses / manual Focus	MS-11D, SS-11D, MS-11, SS-11, MM-11

* Controlled by Digital zoom demand

² legend for logos:

IF Inner Focus **QZ** QuickZoom **ZL** Zoom Limit

▶ XS17x5.5BRM
Broadcast lens



Specifications/Lens	XS17x5.5BRM
Zoom ratio / Format	17x / 1/2"
Focal length	5.5–94 mm
Maximum relative aperture	F1.4 (5.5–77 mm) / F2.4 (94 mm)
Angular field of view 16:9 Aspect ratio	5.5 mm: 64°43'x39°14' / 94 mm: 4°15'x2°23'
M.O.D. (Minimum Object Distance) from front of lens	0.60 m
Object dimensions at M.O.D.	5.5 mm: 741 x 417 mm / 94 mm: 41 x 23 mm
Filter size	ø 82 mm P=0.75
Dia ø x Length (w/o hood)	ø 85 x 206.6 mm
Weight (w/o hood)	1.53 kg
Options	16-bit encoder
Features ²	IF QZ ZL *
Remote set system for -RM lenses / manual Focus	MS-11D, SS-11D, MS-11, SS-11, MM-11

▶ ZS17x5.5BERM
ZS17x5.5BERD
Broadcast lens



Specifications/Lens	ZS17x5.5BERM / ZS17x5.5BERD
Zoom ratio	17x
Focal length	(1x) 5.5 – 94 mm / (2x) 11 – 188 mm
Maximum relative aperture	F1.4 (5.5 – 77 mm) / F1.7 (94 mm)
Angular field of view 16:9 Aspect ratio	5.5 mm: 64°43'x39°14' / 94 mm: 4°15'x2°23'
M.O.D. (Minimum Object Distance) from front of lens	0.60 m
Object dimensions at M.O.D.	5.5 mm: 692 x 389 mm / 94 mm: 42 x 24 mm
Filter size	ø 82 mm P=0.75
Dia ø x Length (w/o hood)	ø 85 x 206.6 mm
Weight (w/o hood)	1.58kg
Options	
Features ²	IF QZ ZL *
Remote set system for -RM lenses / manual Focus	MS-11D, SS-11D, MS-11, SS-11, MM-11
Remote set system for -RD lenses / servo Focus	SS-13D, SS-14S, SS-13A

▶ XS20sx6.3BRM
Professional lens



Specifications/Lens	XS20sx6.3BRM
Zoom ratio	20x
Focal length	(1x) 6.3 – 126 mm
Maximum relative aperture	F1.4 (6.3 – 88 mm) / F2.0 (126 mm)
Angular field of view 16:9 Aspect ratio	6.3 mm: 57°54'x34°34' / 126 mm: 3°10'x1°47'
M.O.D. (Minimum Object Distance) from front of lens	0.30 m
Object dimensions at M.O.D.	6.3 mm: 904 x 508 / 126 mm: 47 x 26 mm
Filter size	ø 82 mm P=0.75
Dia ø x Length (w/o hood)	ø 85 x 181.9 mm
Weight (w/o hood)	1.4kg
Options	
Features ²	IF *
Remote set systems	MM-01, MS-01, SS-01

* Controlled by Digital zoom demand

² legend for logos:

IF Inner Focus **QZ** QuickZoom **ZL** Zoom Limit

► Control Accessories

Model	Type	ø Size	Converter	Mag.	Converter Focal length (mm)	MOD	Weight in kg
XS17x5.5BE	Tele	85 mm	TCV-H85	1.5x	94.0 – 141.0	1.35	1.10
	Wide	85 mm	WCV-H85	0.8x	5.5 – 4.4	0.38	1.05
	Wide	85 mm	WAT-H85	0.7x	5.5 – 3.8	0.29	0.36
	Fish Eye	85 mm	F-ATH85	0.57x	5.5 – 3.8	0.19	0.36
ZS17x5.5BE	Tele	85 mm	TCV-H85	1.5x	94.0 – 141.0	1.35	1.10
	Wide	85 mm	WCV-H85	0.8x	5.5 – 4.4	0.38	1.05
	Wide	85 mm	WAT-H85	0.7x	5.5 – 3.8	0.29	0.36
	Fish Eye	85 mm	F-ATH85	0.57x	5.5 – 3.8	0.19	0.36
HS16x4.6BE	Tele	95 mm	TCV-H95	1.5x	74.0 – 111.0	0.90	1.00
	Wide	95 mm	WCV-H95	0.85x	4.6 – 3.9	0.29	1.00
	Wide	95 mm	none	n.a.	n.a.	n.a.	n.a.
	Fish Eye	95 mm	none	n.a.	n.a.	n.a.	n.a.
HS18x5.5BE HSS18x5.5B	Tele	85 mm	TCV-H85	1.5x	100.0 – 150.0	1.35	1.10
	Wide	85 mm	WCV-H85	0.8x	5.5 – 4.4	0.38	1.05
	Wide	85 mm	WAT-H85	0.7x	5.5 – 3.8	0.29	0.36
	Fish Eye	85 mm	F-ATH85	0.57x	5.5 – 3.8	0.19	0.36
XS13x3.3B	Tele	95 mm	none	n.a.	n.a.	n.a.	n.a.
	Wide	95 mm	none	n.a.	n.a.	n.a.	n.a.
	Wide	95 mm	none	n.a.	n.a.	n.a.	n.a.
	Fish Eye	95 mm	none	n.a.	n.a.	n.a.	n.a.
XS20sx6.3B	Tele	85 mm	none	n.a.	n.a.	n.a.	n.a.
	Wide	85 mm	WCV – X85	0.8x	6.3 – 5.0	0.58	0.75
	Wide	85 mm	none	none	n.a.	n.a.	n.a.
	Fish Eye	85 mm	none	n.a.	n.a.	n.a.	n.a.

► HD/ENG lens converters

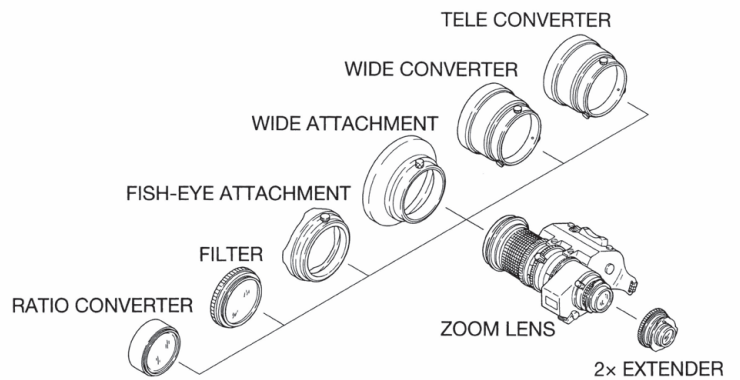
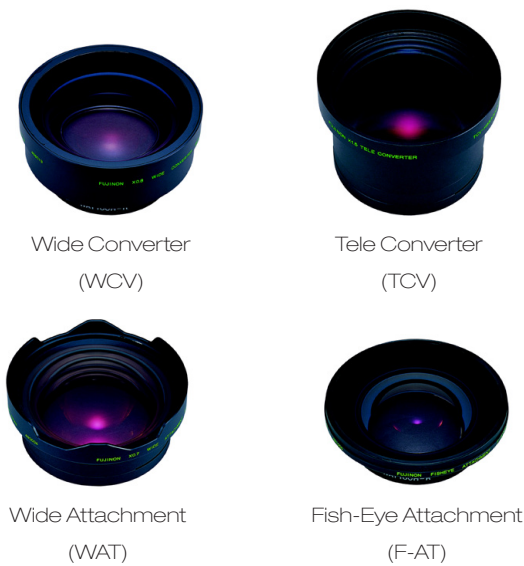

► Digi Power rear control kits/Broadcast lenses

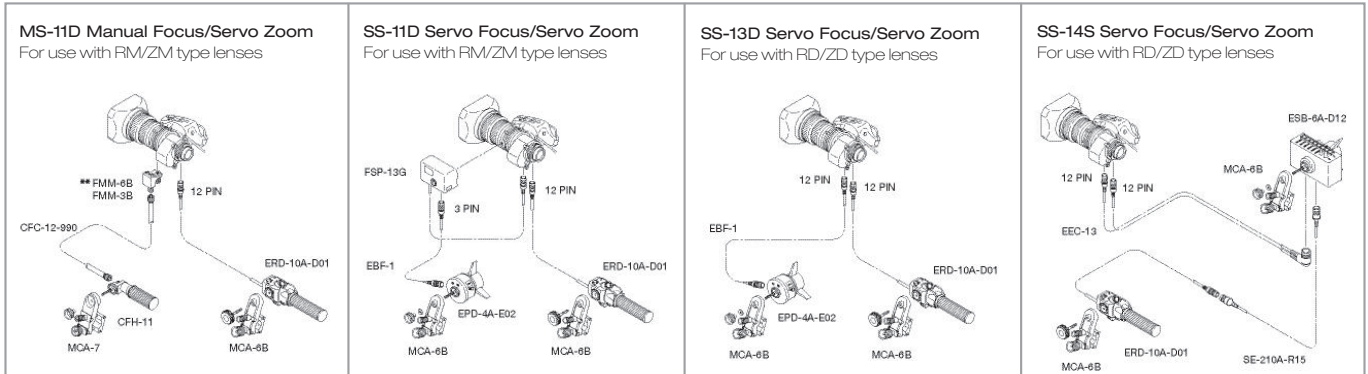

► Standard rear control kits/Broadcast lenses

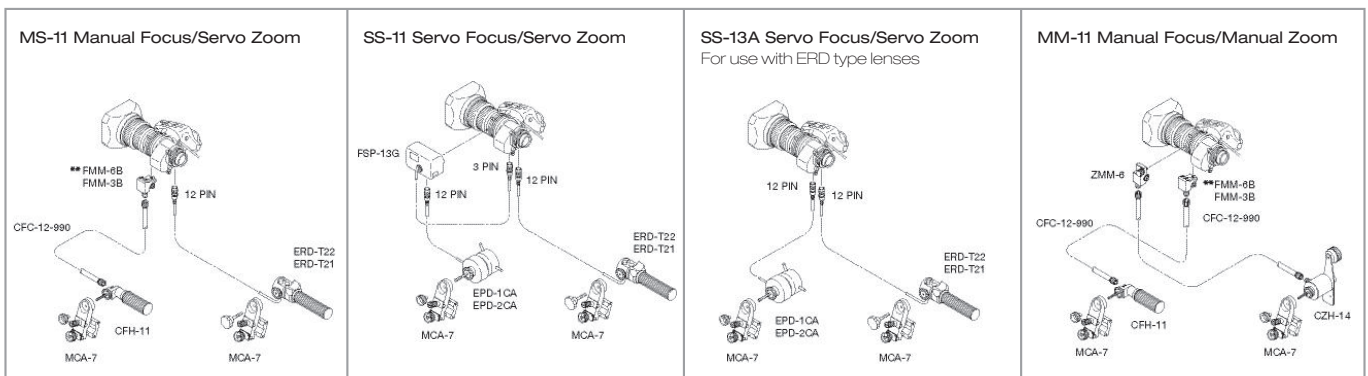

► Professional control kits

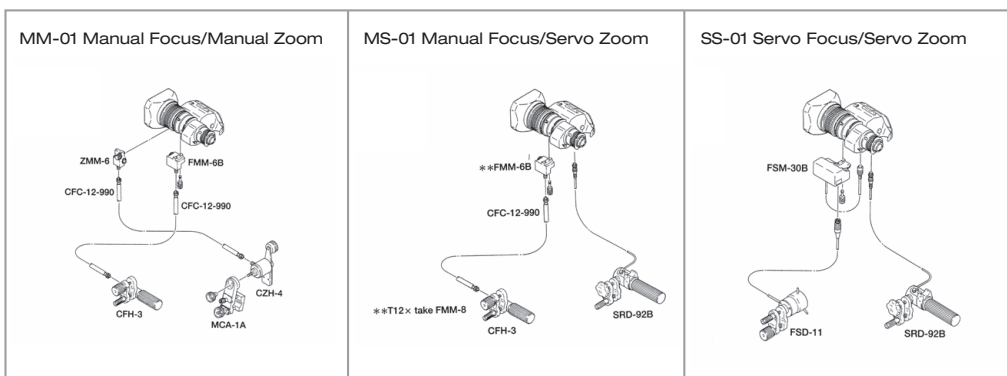

Specifications are subject to change without notice. 01/12