

SENTECH

12 MP High Speed CL Series Product Specifications



Features

- 12 Megapixel Resolution
- High Speed Camera Link Output
- Monochrome or Color Models
- Power over Camera Link

Contents

1	OVERVIEW	5
1.1	FEATURES	5
1.2	NAMING METHOD	5
2	SPECIFICATIONS	6
2.1	ELECTRONIC SPECIFICATIONS / MECHANICAL SPECIFICATIONS / ENVIRONMENTAL SPECIFICATIONS	6
2.1.1	STC- CMC120APCL (Monochrome / Color)	6
2.2	SPECTRAL SENSITIVITY CHARACTERISTICS	7
2.2.1	STC-CMC120APCL/ STC-CMB120APCL	7
2.3	CONNECTOR SPECIFICATIONS	8
2.3.1	Camera Link Connectors:	8
2.4	POWER/IO CONNECTOR	9
2.5	DIMENSIONS	12
2.6	ACCURACY OF SENSOR POSITION	13
3	CAMERA INSTALLATION	14
4	CAMERA OUTPUT TIMING CHARTS	15
4.1	HORIZONTAL TIMINGS (CMC120APCL)	15
4.1.1	10 Taps (1X10-1Y) / Horizontal : 4,090 pixels	15
4.1.2	8 Taps (1X8-1Y) / Horizontal 4,096 pixels	17
4.1.1	4 Taps (1X4-1Y) / Horizontal : 4,096 pixels	19
4.1.1	3 Taps (1X3-1Y) / Horizontal 4,092 pixels	20
4.1.2	2 Taps (1X2-1Y) / Horizontal : 4,096 pixels	20
4.2	VERTICAL TIMINGS	21
4.3	FULL SCAN (STC-CMC120APCL / STC-CMB120APCL)	21
4.4	AOI OUTPUT TIMING	22
4.5	CAMERA LINK BIT ASSIGNMENT	25
4.6	CAMERA LINK TAP GEOMETRY	29
4.6.1	10TAP (1X10-1Y)	29
4.6.2	8TAP (1X8-1Y)	29
4.6.3	4TAP (1X4-1Y)	30
4.6.4	2TAP (1X2-1Y)	30
4.7	BAYER PATTERN FOR COLOR MODEL (STC-CMC120APCL)	31
5	CAMERA FUNCTION MODES	32
5.1	NORMAL MODE	32
5.1.1	Normal Mode (Electronic shutter)	32
5.2	PULSE WIDTH TRIGGER MODE	33
5.2.1	Pulse Width Trigger Mode	33
5.2.2	Pulse Width Trigger Mode (Exposure Timing)	34
5.3	EDGE PRESET TRIGGER MODE	35
5.3.1	Edge Preset Trigger Mode	35
5.3.2	Edge Preset Trigger Mode (Exposure timing)	36
6	COMMUNICATION PROTOCOL SPECIFICATIONS	37
6.1	COMMUNICATION METHOD	37
6.2	COMMUNICATION SETTINGS	37
6.3	COMMUNICATION FORMAT	38

6.4	CAMERA CONTROL COMMANDS	40
6.4.1	Camera Commands List (Device Code:00H).....	40
6.4.2	Description of the Camera Control Commands	43
6.4.3	Camera Control Command List (Device Code:3AH)	52
8	CONTROL SOFTWARE.....	57
8.1	SUMMARY.....	57
8.1.1	File.....	58
8.1.2	Comm.....	58
8.1.3	Mode	59
8.1.4	Help	59
8.2	SOFTWARE FUNCTION (STANDARD)	59
8.2.1	Shutter.....	59
8.2.2	Mode	60
8.2.3	Gain.....	61
8.2.4	Serial Communication	61
8.2.5	Flip.....	61
8.2.6	Other	61
8.3	SOFTWARE FUNCTION (PARTIAL)	62
8.4	SOFTWARE FUNCTION (ADVANCED)	62
8.5	SOFTWARE FUNCTION (HDR).....	62
8.6	SOFTWARE FUNCTION (SP PIN).....	62
9	ACTUAL CAMERA SETTING & TECHNICAL NOTES.....	63
9.1	USING THE TRIGGER SIGNAL THROUGH 6PIN	63
10	REVISION HISTORY	64

Product Precautions

- Handle the camera with care. Do not abuse the camera. Avoid striking or shaking it. Improper handling or storage could damage the camera.
- Do not pull or damage the camera cable.
- During camera use, do not wrap the unit in any material. This will cause the internal temperature of the unit to increase.
- Do not expose the camera to moisture, or do not try to operate it in wet areas.
- Do not operate the camera beyond its temperature, humidity and power source ratings.
- While the camera is not being used, keep the lens or lens cap on the camera to prevent dust or contamination from getting in the CCD or filter area and scratching or damaging this area.
- Do not keep the camera under the following conditions:
 - In wet, moist, and high humidity areas
 - Under hot direct sunlight
 - In high temperature areas
 - Near an object that releases a strong magnetic or electric field
 - Areas with strong vibrations
- Apply the power that satisfies the requirements specified in this document to the camera.
- Use a soft cloth to clean the camera. Use pressured air spray to clean the surface of the glass. DO not scratch the surface of the glass.
- The camera is a general-purpose electronic device; using the camera for the equipment that may threaten human life or cause dangers to human bodies directly in case of failure or malfunction of the camera is not guaranteed. Use the camera for special purposes at your own risk.

1 Overview

This document describes the specifications of the following cameras:

STC-CMC120APCL	(12M Color)
STC-CMB120APCL	(12M Monochrome)

1.1 Features

- 12M pixel (4096 x 3072)
- CMOS Sensor (Global Shutter)
- Camera Link (Deca, Full, Medium, Base Configuration)
- 10,8,4,3,2TAP
- PoCL (Power Over Camera Link)

This Camera Link camera features a 12M pixel CMOS sensor and supports a maximum frame rate of 62.3fps on 12M pixel(8bit, 10TAP mode).

1.2 Naming Method

STC-CMx120APCL

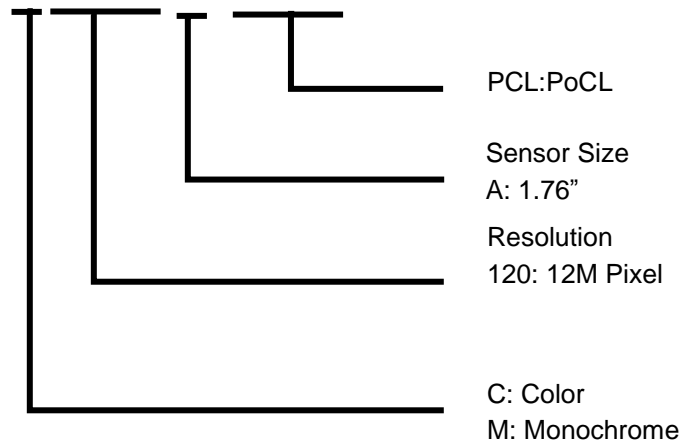

Figure 1: Naming Method

2 Specifications

2.1 Electronic Specifications / Mechanical Specifications / Environmental Specifications

2.1.1 STC- CMC120APCL (Monochrome / Color)

Product		STC-CMC120APCL	STC-CMB120PCL	
Electronic Specifications	Imager	1.76 " Type 12Meg color progressive CMOS (CMOSIS: CMV12000)	1.76" Type 12Meg monochrome progressive CMOS (CMOSIS: CMV2000)	
	Shutter	Global Shutter		
	Active picture elements	4090 (H) x 3072 (V): 10TAP 4096 (H) x 3072 (V): 8TAP,4TAP,2TAP 4092 (H) x 3072 (V): 3TAP		
	Chip size	22.5 x 16.9 mm		
	Cell size	5.5 (H) x 5.5 (V) μm		
	Scanning system	Progressive		
	Scanning method	Full scanning, Variable AOI	Full scanning, Variable AOI	
	Frame rate Vertical frequency of the Camera Link output	62.3Hz(8bit 10TAP), 51.8Hz (8bit 8TAP), 25.9Hz (8/10/12bit 4TAP), 19.4Hz (8bit 3TAP), 12.9Hz (8/10/12bit 2TAP)		
	Pixel frequency	10TAP, 8TAP,4TAP,3TAP,2TAP: 85MHz or 42.5MHz (Selectable)		
	Noise level	8bit output	TBD	
	Minimum scene illumination	Typical 1.4 Lux at F2.25 (10TAP)	Typical TBD Lux at F2.25 (10TAP)	
	Sync. System	Internal		
	Video output	8bit: 10TAP, Full, Medium, Base Configuration 10bit: Base Medium Configuration 12bit: Base Configuration		
	Shutter speed	10,8,4,2TAP : 41[us] to TBD [s] (Variable at Line unit, Pulse Width Trigger),42[us] to TBD [s] (Variable us unit) 3TAP : 42[us] to TBD [s] (Variable at Line unit, Pulse Width Trigger),43[us] to TBD [s] (Variable us unit)		
	Digital gain	1 to x5		
	Gamma	1.0		
	Trigger Mode	Edge Preset Trigger(V Reset), Pulse Width Trigger (V Reset)		
	Power	Input voltage	12Vdc ± 10%	
		Consumption	10TAP, Full Configuration: Less than 7.0 W Base Configuration: Less than 5.0W	
	Communication	RS232 via Camera Link connector		
Mechanical Specifications	Dimensions	68 (W) x 68 (H) x 40 (D) mm (Excluding the connector)		
	Optical filter	No IR cut filter		
	Material	Aluminum alloy		
	Lens mount	M42 mount (F mount with adopter) FB = 10.0mm(in Air)		
	Interface connector	Camera Link connector: SDR connector x 2 Power/IO connector: HR10A-7R-6PB (Hirose) or equivalent		
	Weight	Approximately 305g		
Environmental Specifications	Operational temperature	-5 to 40 deg. C		
	Storage temperature	-30 to 70 deg. C		
	Vibration	20Hz to 200Hz to 20Hz (5min./cycle), acceleration 10G, XYZ 3 directions 30 min. each)		
	Shock	Acceleration 38G, half amplitude 6ms, XYZ 3 directions 3times each		
	Standard compliancy	EMS: EN61000-6-2, EMI: EN55022 (Class B)		
	RoHS	RoHS compliance		

Table 1: Specifications

2.2 Spectral Sensitivity Characteristics

2.2.1 STC-CMC120APCL/ STC-CMB120APCL

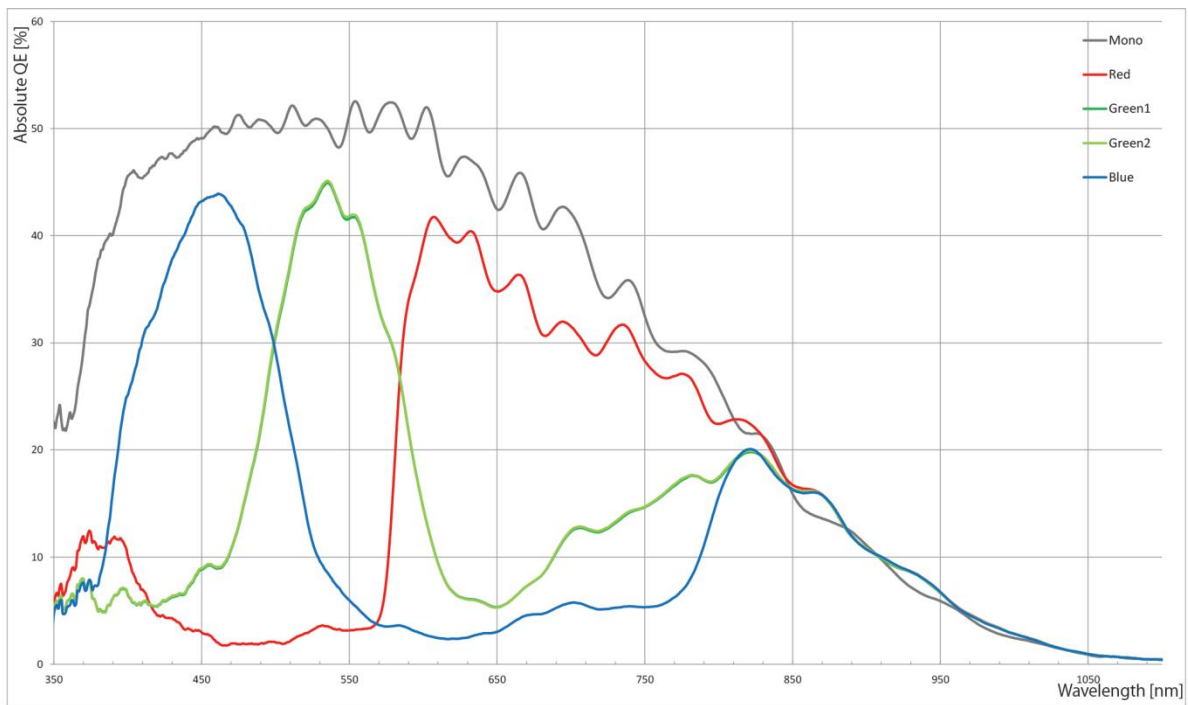
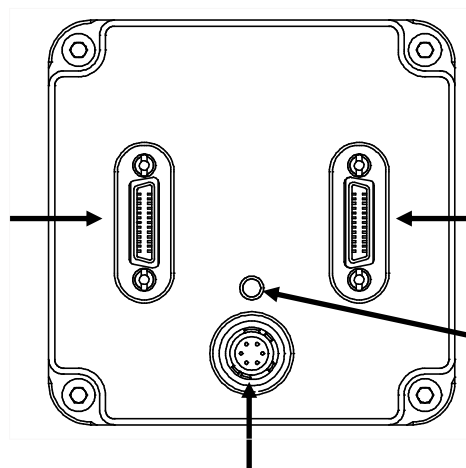

Figure 2: Spectral Sensitivity Characteristics

2.3 Connector Specifications

CH1:
26-pin SDR connector
(Base Camera Link Connector)



CH2
26-pin SDR connector
(Medium / Full Camera
Link Connector)

LED

Power/IO connector

Figure 3: Back View

2.3.1 Camera Link Connectors: SDR (3M) equivalent x 2

(CAUTION)

This product is a PoCL type.

When the frame grabber board and the cable are compatible with PoCL, the frame grabber board supplies the power to the camera. In this case, please DO NOT supply the power through the Power/IO connector.

Pin assignment

Pin No.	Signal Name	Pin No.	Signal Name
1	+12V	14	GND
2	X0-	15	X0+
3	X1-	16	X1+
4	X2-	17	X2+
5	Xclk-	18	Xclk+
6	X3-	19	X3+
7	SerTC+	20	SerTC-
8	SerTFG-	21	SerTFG+
9	CC1- (TRG)	22	CC1+ (TRG)
10	CC2+	23	CC2-
11	CC3-	24	CC3+
12	CC4+	25	CC4-
13	GND	26	+12V

Pin No.	Signal Name	Pin No.	Signal Name
1	+12V	14	GND
2	Y0-	15	Y0+
3	Y1-	16	Y1+
4	Y2-	17	Y2+
5	Yclk-	18	Yclk+
6	Y3-	19	Y3+
7	100Ω	20	100Ω
8	Z0-	21	Z0+
9	Z1-	22	Z1+
10	Z2-	23	Z2+
11	Zclk-	24	Zclk+
12	Z3-	25	Z3+
13	GND	26	+12V

Table 2: CN1:Base Camera Link Connector

CN2:Medium/Full Camera Link Connector

2.4 Power/IO Connector:

HR10A-7R-6PB (Hirose) or equivalent.

This connector is for the 12Vdc power input and the input and output signals.

The trigger input and sync input /output signals can be assigned through the camera setting communication.

Pin assignment

Pin No	Signal Name	IN/OUT	Voltage		
				LowVoltage	HighVoltage
1	GND	IN	0V		
2	SP-4	IN/OUT	IN	0 ~ +0.99V	+2.3 ~ +3.6V
			OUT	0V	+3.3V
3	SP-3	IN/OUT	IN	0 ~ +0.99V	+2.3 ~ +3.6V
			OUT	0V	+3.3V
4	SP-2	IN/OUT	IN	0 ~ +0.99V	+2.3 ~ +3.6V
			OUT	0V	+3.3V
5	SP-1	IN/OUT	IN	0 ~ +0.99V	+2.3 ~ +3.6V
			OUT	0V	+3.3V
6	+12Vdc	IN	+12Vdc		

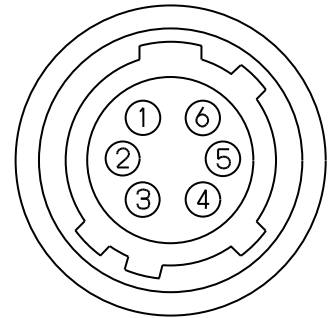

Table 3: Pin assignment

(Note 1)

The trigger input signal can be assigned either on the Camera Link connector (CC1) or on the No. 2 pin of the power/IO connector through the camera setting communication.

For further details please refer to section: [9.1 Using the Trigger Signal through 6pin.](#)

Input Signal Circuit

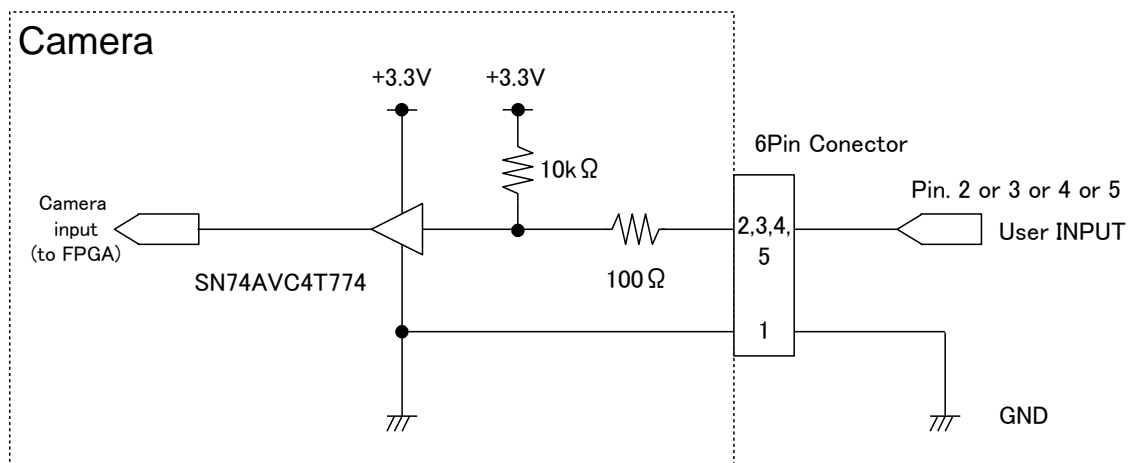

Figure 4: Input Signal Circuit

Input Signal Circuit Example

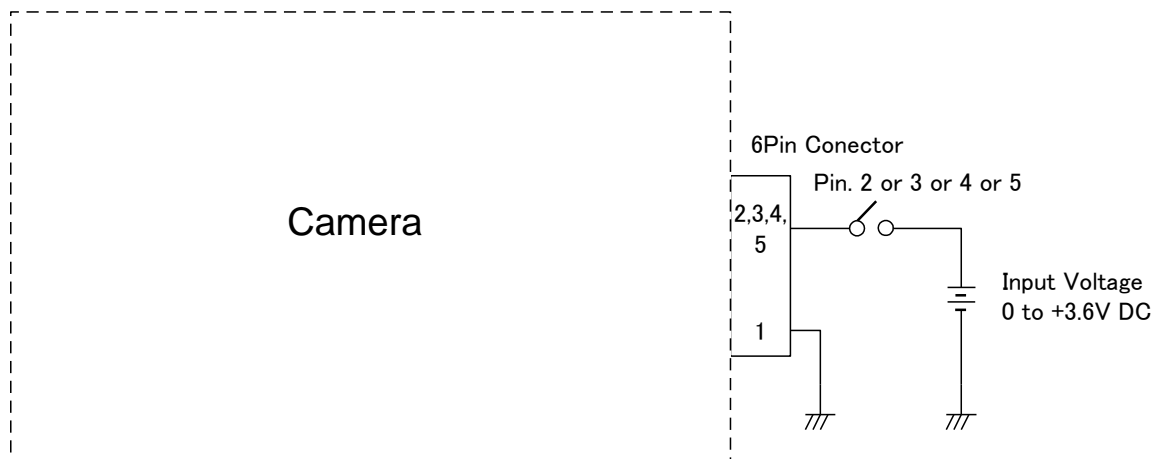

Figure 5: Input Signal Circuit Example

Output Signal Circuit/ Example

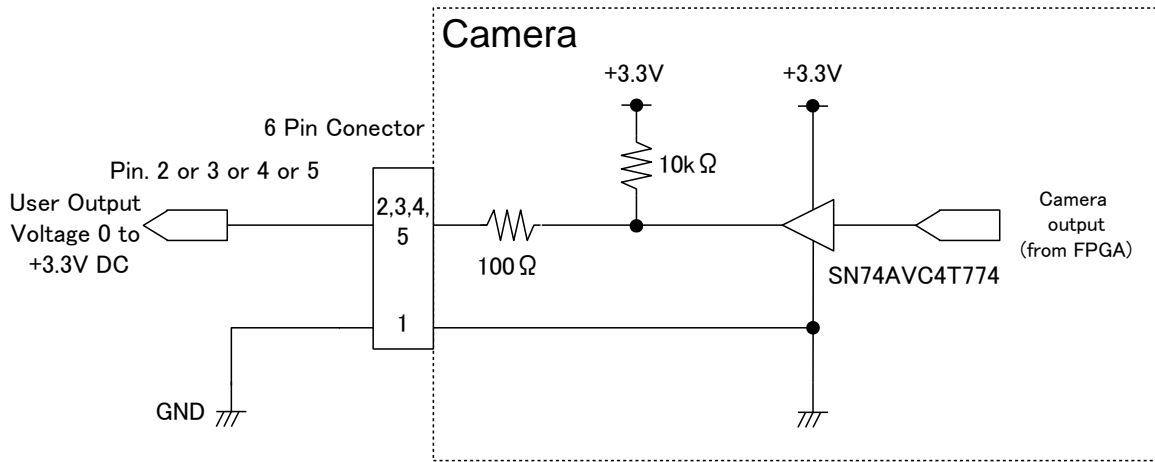

Figure 6: Output Signal Circuit Example

LED information

Mode setting	LED
D9H.0 = 1	OFF
Trigger mode	On 1 second then Off 1 second (repeatedly)
Free run	ON

Table 4: LEC Information

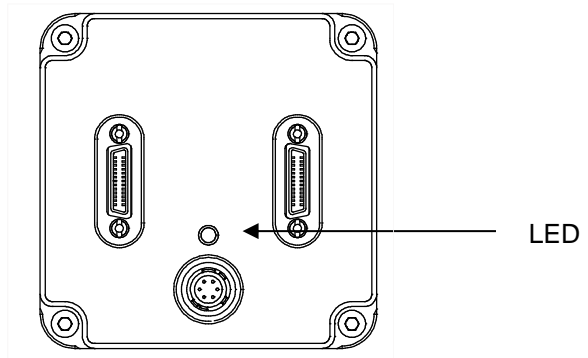
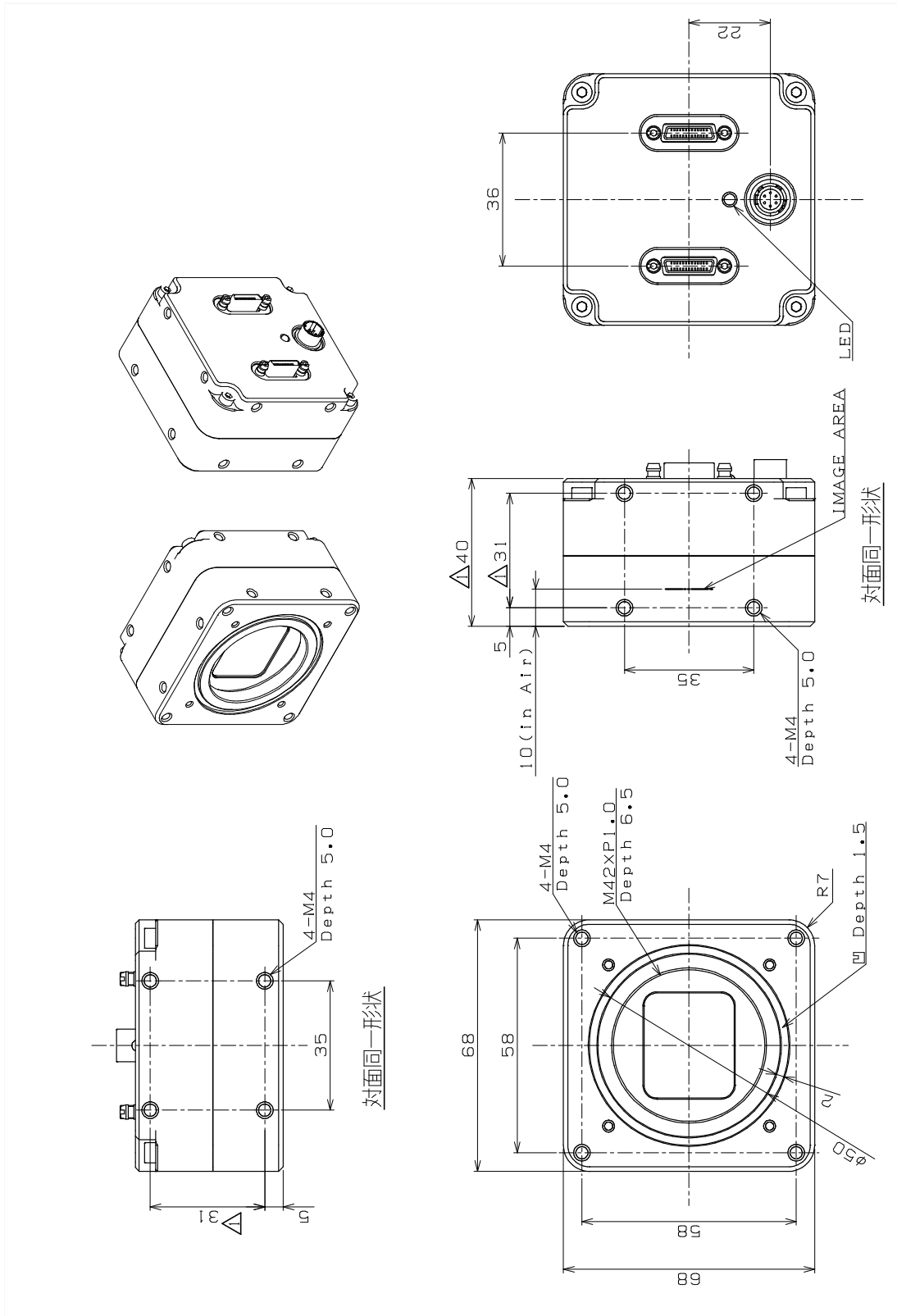

Figure 7 LED Location

2.5 Dimensions

M42 Mount Model



Unit: mm

Figure 8: M42 Mount Model

F Mount Model

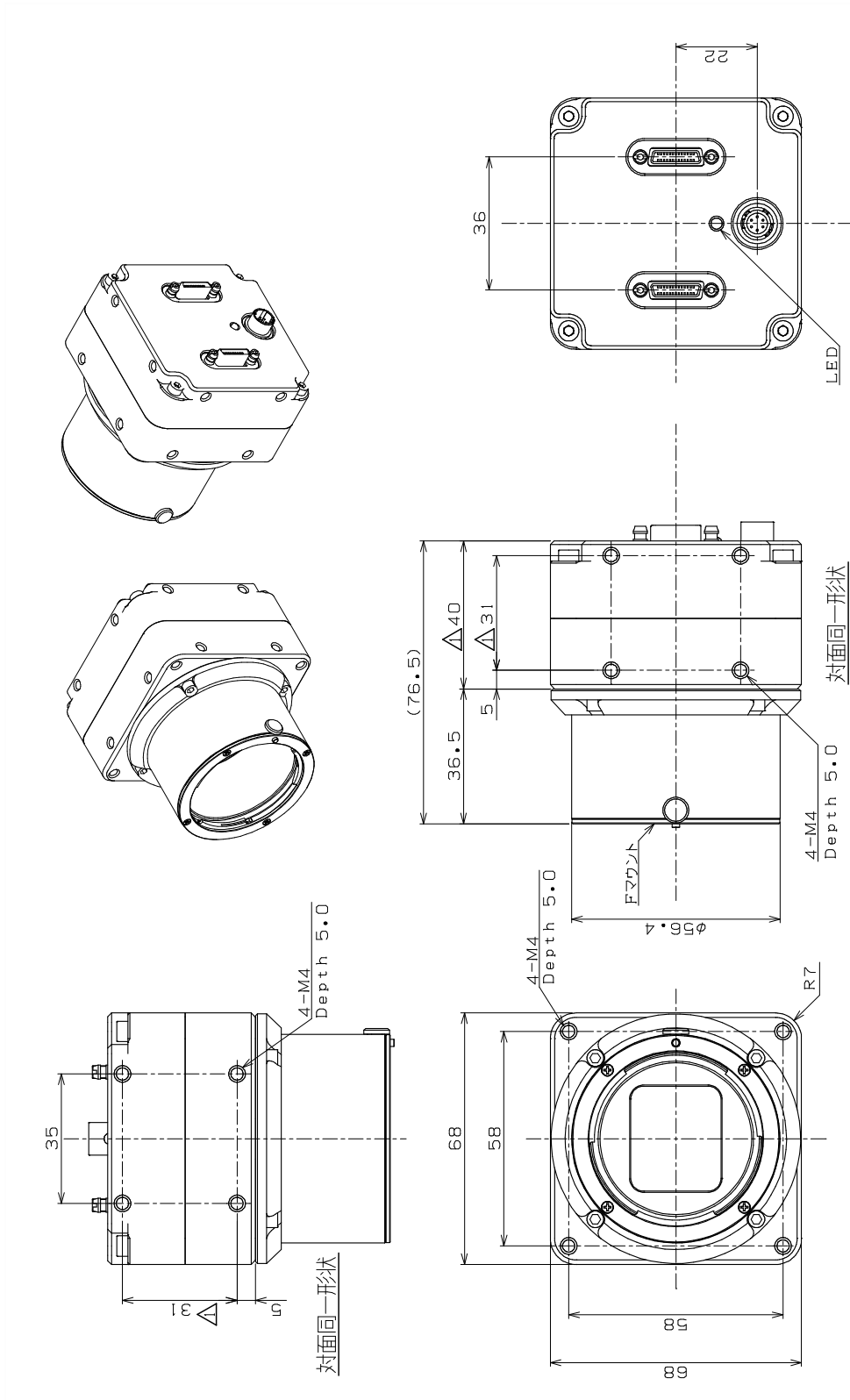

Unit: mm

Figure 9: F Mount Model

2.6 Accuracy of Sensor Position

TBD

3 Camera Installation

The following equipment is required when installing the camera:

- Control software or Serial communication software to access the camera register.
For further details on using the control software, please refer to section: [7](#).

[CONTROL](#) Software. For further details on accessing the camera register, please refer to section:
[6.COMMUNICATION PROTOCOL SPECIFICATIONS](#).

- Camera Link Cable x 2 (SDR Connector : Camera side)
When using the camera with Full Configuration, please ensure that the cable is compatible.
- The frame grabber should support **Full, Medium, Base Configuration**. When using PoCL, the frame grabber should support PoCL.

4 Camera Output Timing Charts

4.1 Horizontal Timings (CMC120APCL)

For further details, please refer to section: [4.2 VERTICAL TIMINGS](#).
 Highs Speed Clock and Low Speed Clock exist as the Pixel Clock.

4.1.1 10 Taps (1X10-1Y) / Horizontal : 4,090 pixels

1 CLK = 11.764 nseconds (85MHz)

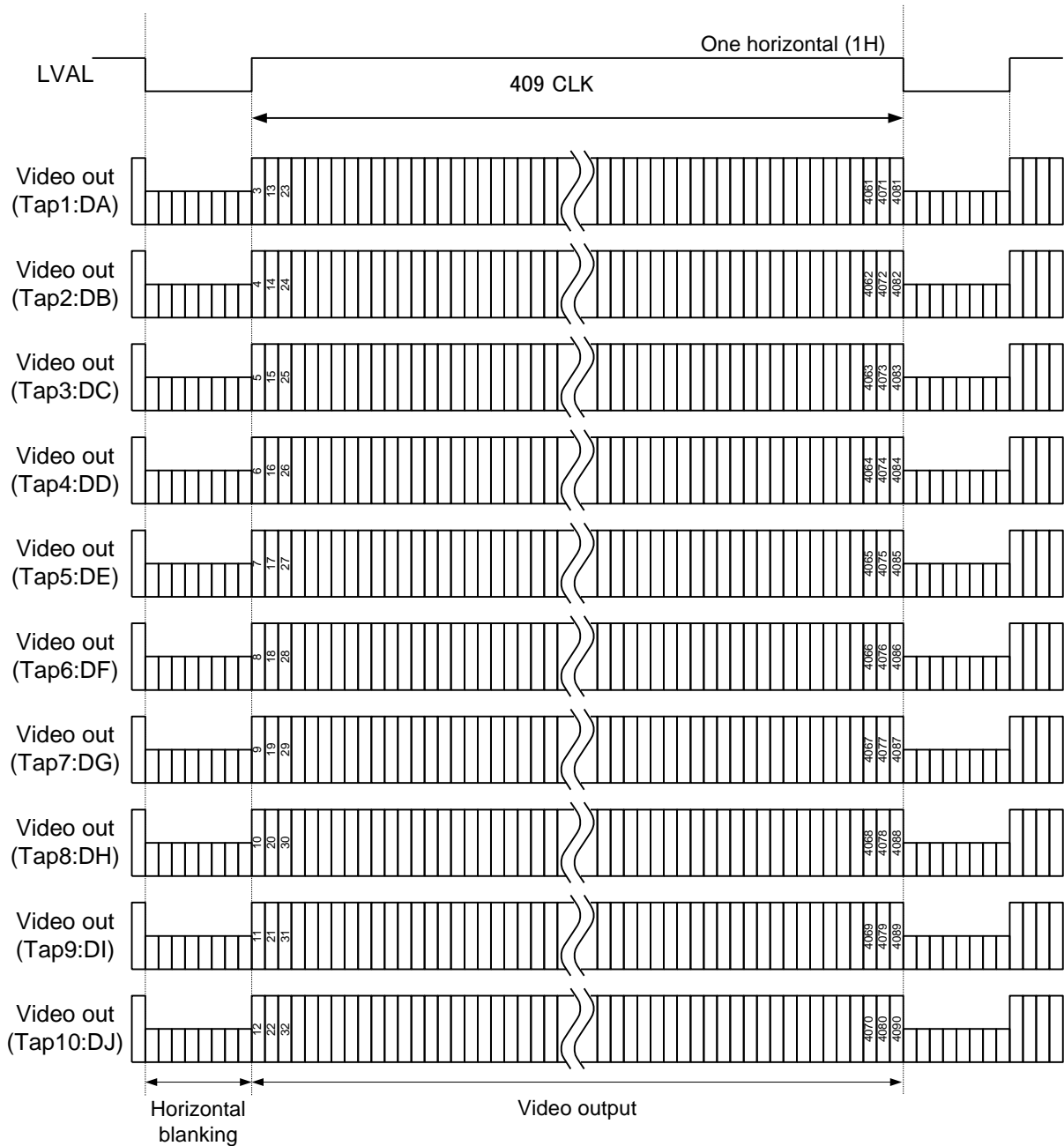

The pixel order for the Image

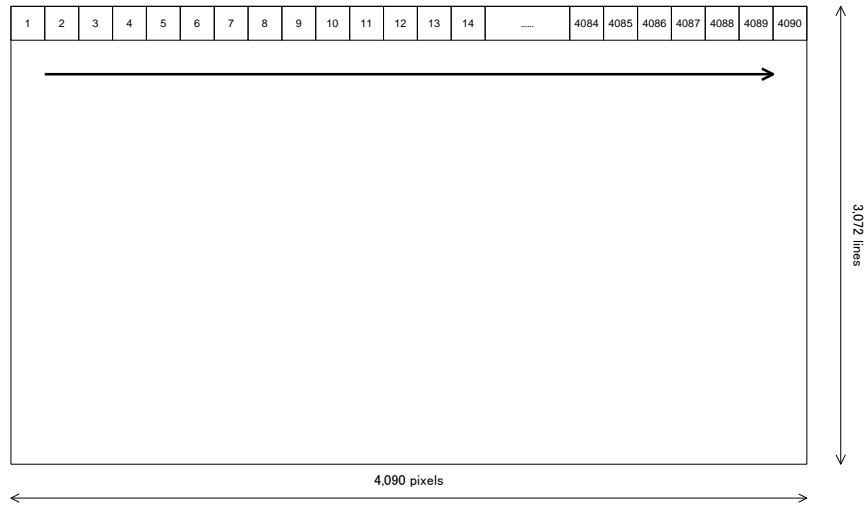

TAP1: DA output pixels

3	13	23	33	43	53	63	4021	4031	4041	4051	4061	4071	4081
---	----	----	----	----	----	----	-------	------	------	------	------	------	------	------

TAP2: DB output pixels

14	24	34	44	54	64	74	4022	4032	4042	4052	4062	4072	4082
----	----	----	----	----	----	----	-------	------	------	------	------	------	------	------

TAP3: DC output pixels

5	15	25	35	45	55	65	4023	4033	4043	4053	4063	4073	4083
---	----	----	----	----	----	----	-------	------	------	------	------	------	------	------

TAP4: DD output pixels

6	16	26	36	46	56	66	4033	4034	4044	4054	4064	4074	4084
---	----	----	----	----	----	----	-------	------	------	------	------	------	------	------

TAP5: DE output pixels

7	17	27	37	47	57	67	4025	4035	4045	4055	4065	4075	4085
---	----	----	----	----	----	----	-------	------	------	------	------	------	------	------

TAP6: DF output pixels

8	18	28	38	48	58	68	4026	4036	4046	4056	4066	4076	4086
---	----	----	----	----	----	----	-------	------	------	------	------	------	------	------

TAP7: DG output pixels

9	19	29	39	49	59	69	4027	4037	4047	4057	4067	4077	4087
---	----	----	----	----	----	----	-------	------	------	------	------	------	------	------

TAP8: DH output pixels

10	20	30	40	50	60	70	4028	4038	4048	4058	4068	4078	4088
----	----	----	----	----	----	----	-------	------	------	------	------	------	------	------

TAP9: DG output pixels

11	21	31	41	51	61	71	4029	4039	4049	4059	4069	4079	4089
----	----	----	----	----	----	----	-------	------	------	------	------	------	------	------

TAP10: DH output pixels

12	22	32	42	52	62	72	4030	4040	4050	4060	4070	4080	4090
----	----	----	----	----	----	----	-------	------	------	------	------	------	------	------

4.1.2 8 Taps (1X8-1Y) / Horizontal 4,096 pixels

1 CLK = 11.764 nseconds(85MHz)

1 CLK = 23.524 nseconds(42.5MHz)

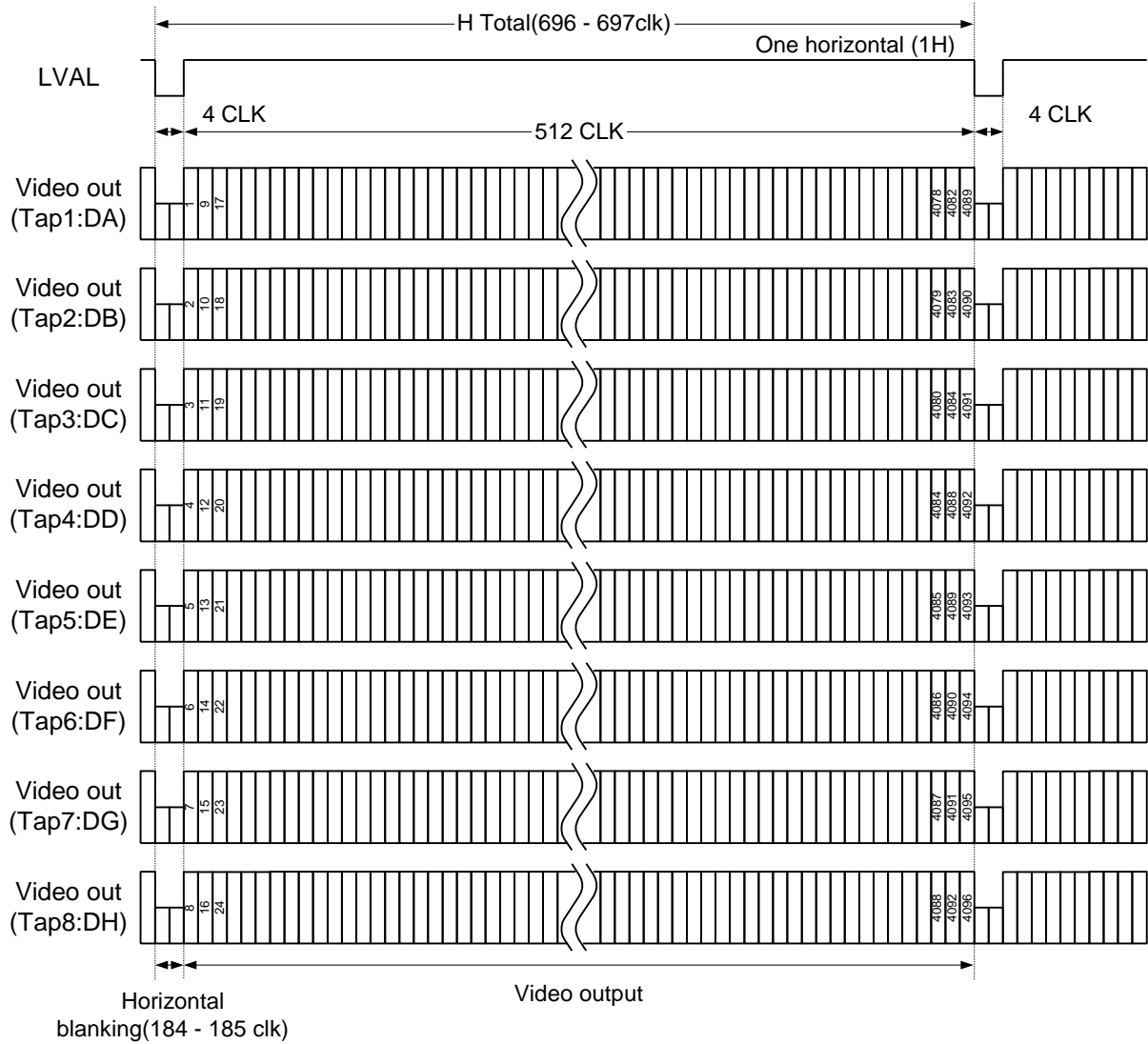

The pixel order for the Image

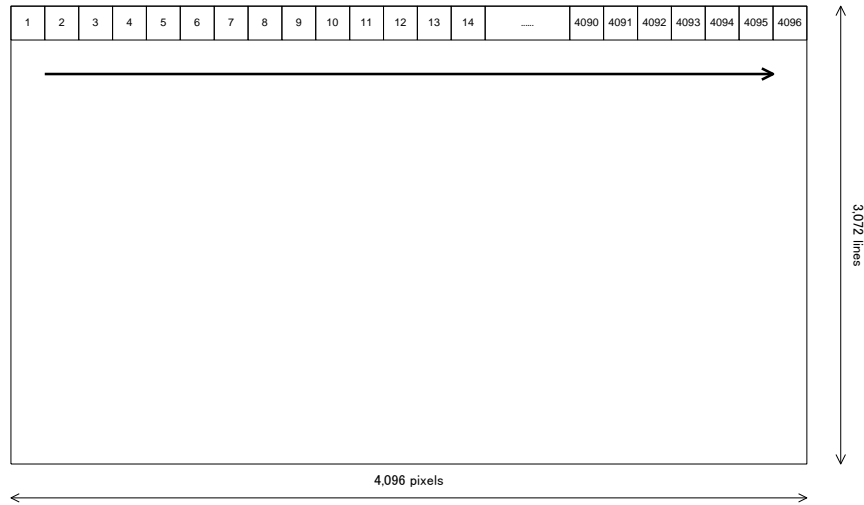

TAP1: DA output pixels	1	9	17	25	33	41	49	4041	4049	4057	4065	4073	4081	4089
TAP2: DB output pixels	2	10	18	26	34	42	50	4042	4050	4058	4066	4074	4082	4090
TAP3: DC output pixels	3	11	19	27	35	43	51	4043	4051	4059	4067	4075	4083	4091
TAP4: DD output pixels	4	12	20	28	36	44	52	4044	4052	4060	4068	4076	4084	4092
TAP5: DE output pixels	5	13	21	29	37	45	53	4045	4053	4061	4069	4077	4085	4093
TAP6: DF output pixels	6	14	22	30	38	46	54	4046	4054	4062	4070	4078	4086	4094
TAP7: DG output pixels	7	15	23	31	39	47	55	4047	4055	4063	4071	4079	4087	4095
TAP8: DH output pixels	8	16	24	32	40	48	56	4048	4056	4064	4072	4080	4088	4096

4.1.1 4 Taps (1X4-1Y) / Horizontal : 4,096 pixels

1 CLK = 11.764 nseconds(85MHz)

1 CLK = 23.524 nseconds(42.5MHz)

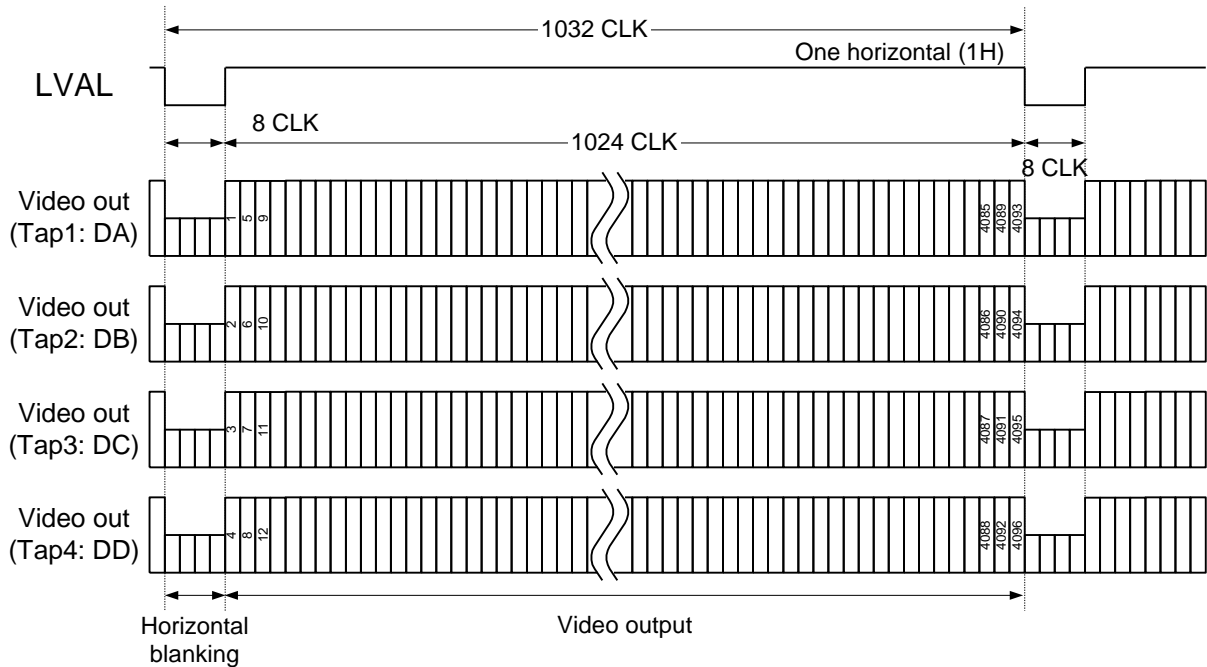

The pixel order for the Image

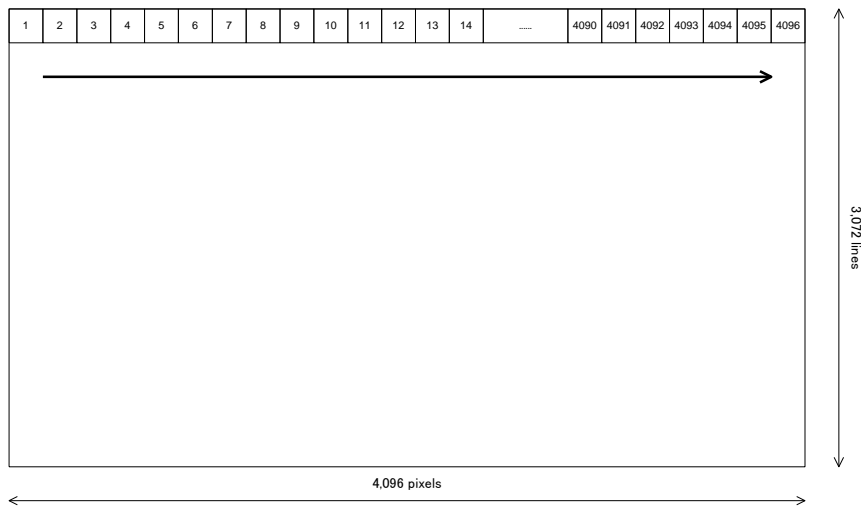

TAP1: DA output pixels

1	5	9	13	17	21	25	4069	4073	4077	4081	4085	4089	4093
---	---	---	----	----	----	----	-------	------	------	------	------	------	------	------

TAP2: DB output pixels

2	6	10	14	18	22	26	4070	4074	4078	4082	4086	4090	4094
---	---	----	----	----	----	----	-------	------	------	------	------	------	------	------

TAP3: DC output pixels

3	7	11	15	19	23	27	4071	4075	4079	4083	4087	4091	4095
---	---	----	----	----	----	----	-------	------	------	------	------	------	------	------

TAP4: DD output pixels

4	8	12	16	20	24	28	4072	4076	4080	4084	4088	4092	4096
---	---	----	----	----	----	----	-------	------	------	------	------	------	------	------

4.1.1 3 Taps (1X3-1Y) / Horizontal 4,092 pixels

1 CLK = 11.764 nseconds(85MHz)
 1 CLK = 23.524 nseconds(42.5MHz)

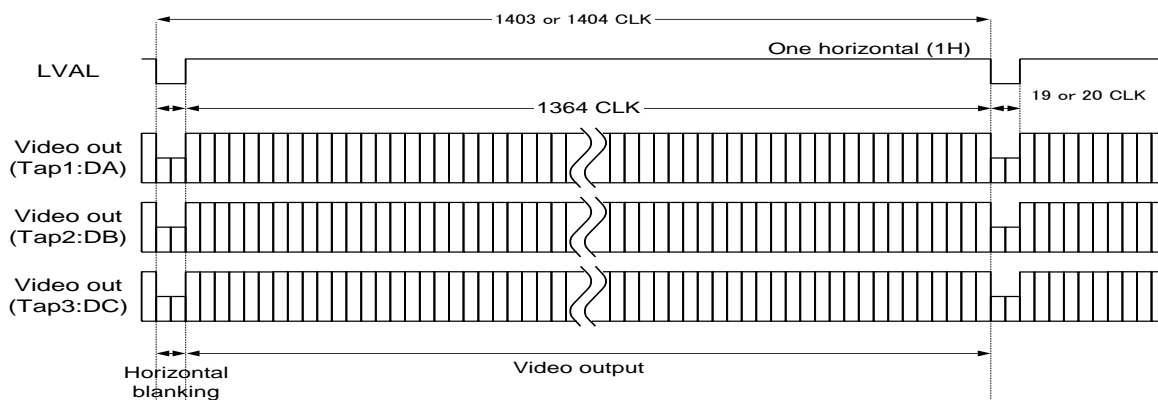

4.1.2 2 Taps (1X2-1Y) / Horizontal : 4,096 pixels

1 CLK = 11.764 nseconds(85MHz)
 1 CLK = 23.524 nseconds(42.5MHz)

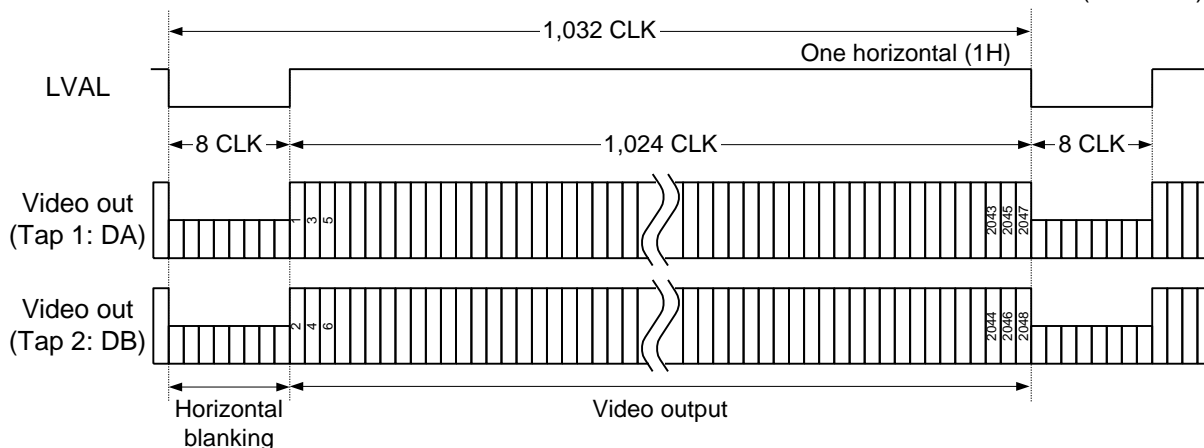

The pixel order for the Image

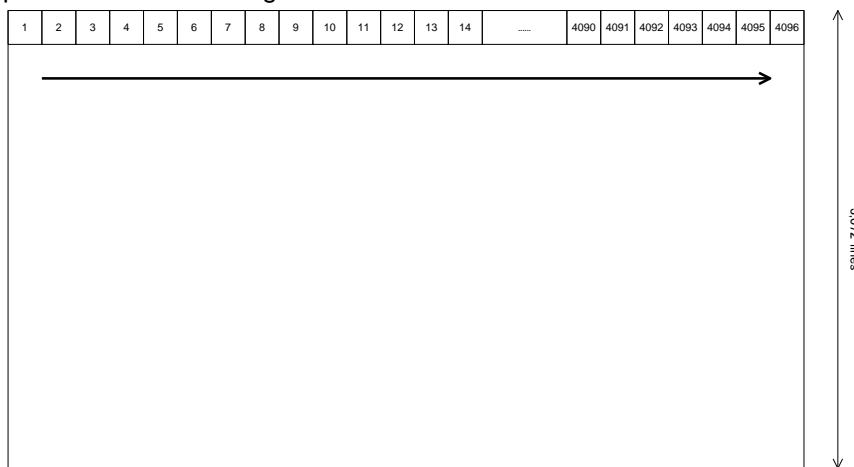

TAP1: DA output pixels

1	3	5	7	9	11	13	4083	4085	4087	4089	4091	4093	4095
---	---	---	---	---	----	----	-------	------	------	------	------	------	------	------

TAP2: DB output pixels

2	4	6	8	10	12	14	4084	4086	4088	4090	4092	4094	4096
---	---	---	---	----	----	----	-------	------	------	------	------	------	------	------

4.2 Vertical Timings

For further details, please refer to section: [4.2 VERTICAL TIMINGS.](#)

Three different video scan modes are shown below:

Full scan: All of the lines and pixels are output from the camera

Binning: The averaged pixel value is output from the camera

Subsampling: Skipped the lines and pixels output from the camera

Overview of Full scan

All of the lines and pixels are output and the entire image is shown. When transmitting the image, some configurations will not be supported, or can drop the frame rate.

4.3 Full Scan (STC-CMC120APCL / STC-CMB120APCL)

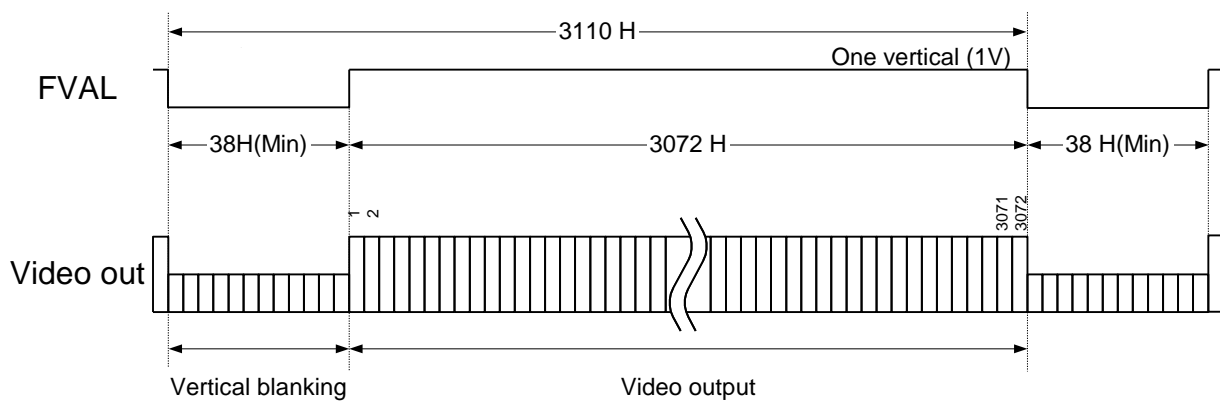

Table of Video Output on Full Scan mode (STC-CMC120APCL / STC-CMB120APCL)

Mode (EEH)	Tap Number	Configuration	CameraLink Output PixelClock Frequency(MHz)	Horizontal Pixel (Pixel)	FPS[fps]	Camera Link Output Bit
0	2	Base	85.0 42.5	4096	12.9 6.4	8/10/12
16	3	Base	85.0 42.5	4092	19.4 9.8	8
1	4	MEDIUM	85.0 42.5	4096	25.9 12.9	8/10/12
2	8	FULL	85.0 42.5	4096	51.8 25.9	8
3	10	DECA	85.0 42.5	4090	62.3 31.1	8

4.4 AOI Output Timing

- This camera can set the AOI up to 8 different regions.
- Variable Partial Start Line (VAS*), Variable Partial Effective Line(VAH*), Horizontal Start Position(HAS*) and Horizontal Effective Pixel(HAW*) can be set for each eight regions. One region can be set on horizontal direction. And the vertical area cannot overlap for each region.

An example of four areas of interest (AOI) are shown below:

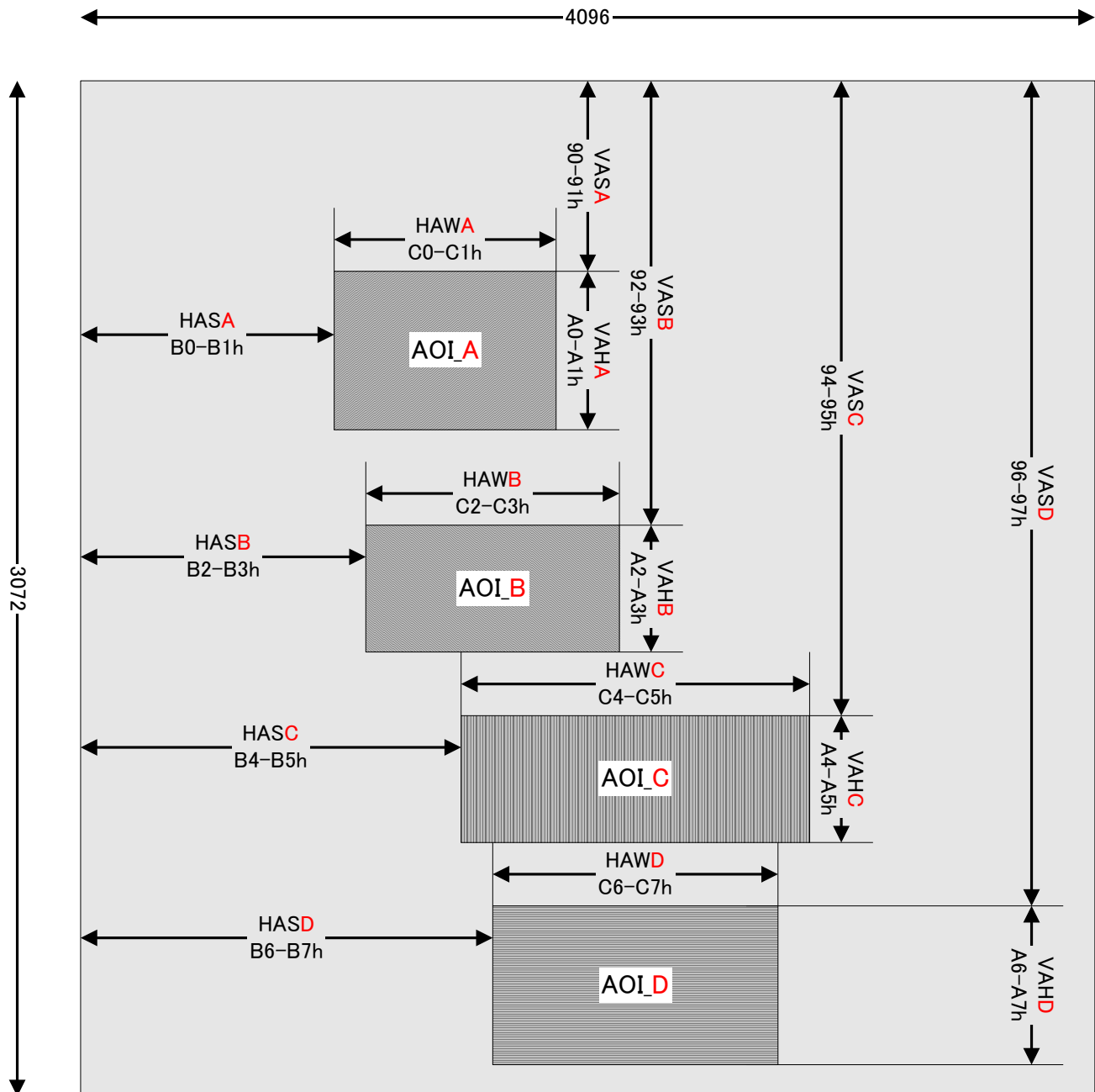

The Camera Link Output timing on AOI is shown below:

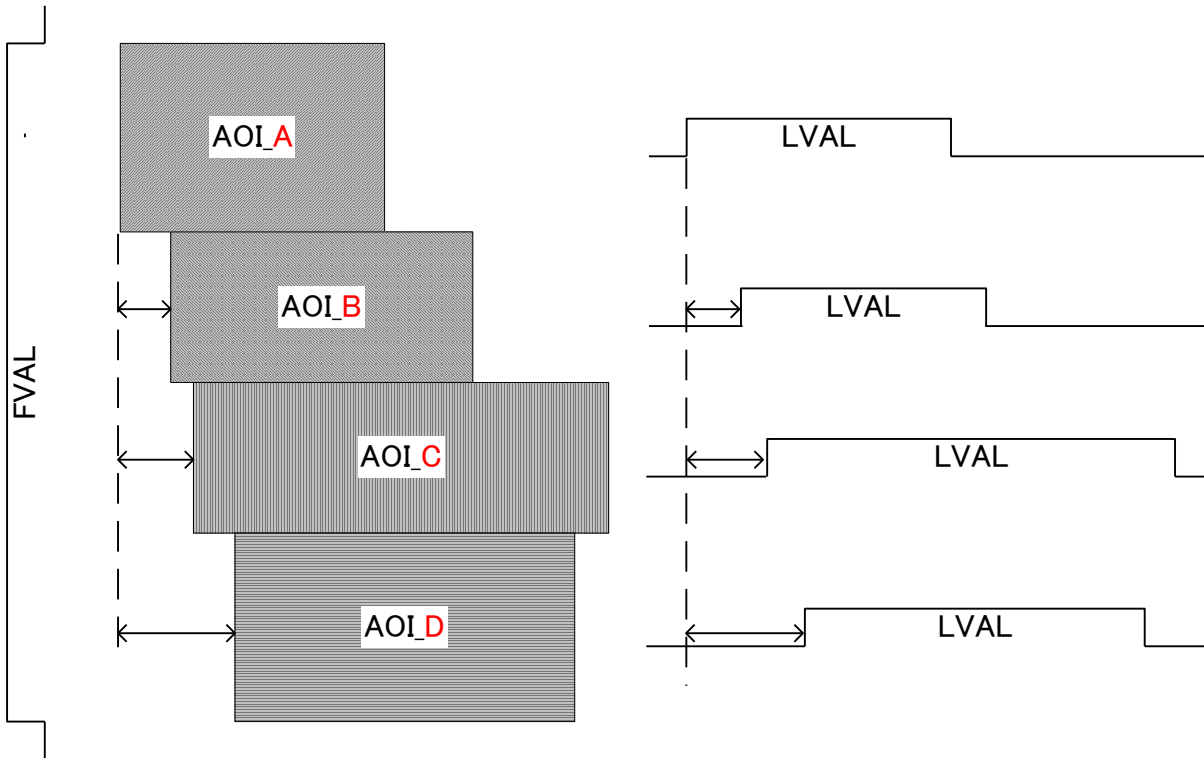

AOI images output as consecutive images.

Horizontal pixel numbers can be reduced through the Horizontal Effective Pixel(HAW*) on AOI.

AOI on Color camera

Variable Partial Start Line(VAS*) and Variable Partial Effective Line(VAH*) can be set to two lines each. Horizontal Start Position(HAS*) and Horizontal Effective Pixel(HAW*) can be set to two pixels each.

Frame rate on AOI

Maximum frame rate can be achieved through Variable Partial Effective Line(VAH*). Horizontal Effective Pixel(HAW*) is not related to the maximum frame rate.

Formula of maximum frame rate

- 10TAP CameraLink Clock: 85MHz
 $50 / 258 / \text{Variable Partial Effective Line(VAH*)} + 38) \times 10^6$ [fps] (Round down numbers beyond the second decimal point)

- 10TAP CameraLink Clock: 42.5MHz
 $25 / 258 / \text{Variable Partial Effective Line(VAH*)} + 38) \times 10^6$ [fps] (Round down numbers beyond the second decimal point)

- 8TAP CameraLink Clock: 85MHz
 $41.6 / 258 / \text{Variable Partial Effective Line(VAH*)} + 38) \times 10^6$ [fps] (Round down numbers beyond the second decimal point)

- 8TAP CameraLink Clock: 42.5MHz, 4TAP CameraLink Clock: 85MHz
 $20.8 / 258 / \text{Variable Partial Effective Line(VAH*)} + 38) \times 10^6$ [fps] (Round down numbers beyond the second decimal point)

- 4TAP CameraLink Clock: 42.5MHz, 2TAP CameraLink Clock: 85MHz
 $10.4 / 258 / \text{Variable Partial Effective Line(VAH*)} + 38) \times 10^6$ [fps] (Round down numbers beyond the second decimal point)

- 2TAP CameraLink Clock: 42.5MHz
 $5.2 / 258 / \text{Variable Partial Effective Line(VAH*)} + 38) \times 10^6$ [fps] (Round down numbers beyond the second decimal point)

- 3TAP CameraLink Clock: 85MHz
 $15.6 / 258 / \text{Variable Partial Effective Line(VAH*)} + 38) \times 10^6$ [fps] (Round down numbers beyond the second decimal point)

- 3TAP CameraLink Clock: 42.5MHz
 $7.8 / 258 / \text{Variable Partial Effective Line(VAH*)} + 38) \times 10^6$ [fps] (Round down numbers beyond the second decimal point)

4.5 Camera Link Bit Assignment

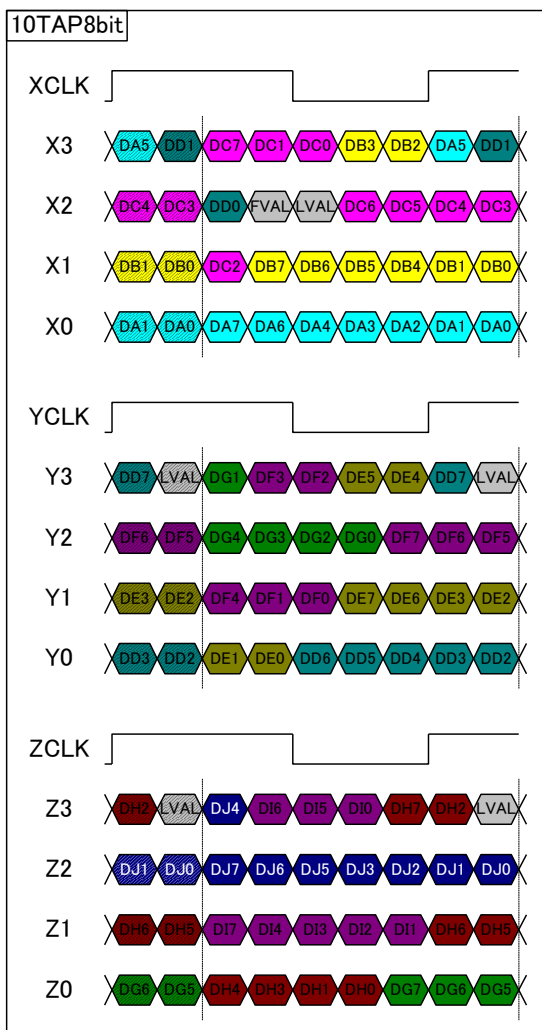

- DA0 to DA7: 8bit data for one pixel from TAP1
- DB0 to DB7: 8bit data for one pixel from TAP2
- DC0 to DC7: 8bit data for one pixel from TAP3
- DD0 to DD7: 8bit data for one pixel from TAP4
- DE0 to DE7: 8bit data for one pixel from TAP5
- DF0 to DF7: 8bit data for one pixel from TAP6
- DG0 to DG7: 8bit data for one pixel from TAP7
- DH0 to DH7: 8bit data for one pixel from TAP8
- DI0 to DI7: 8bit data for one pixel from TAP9
- DJ0 to DJ7: 8bit data for one pixel from TAP10

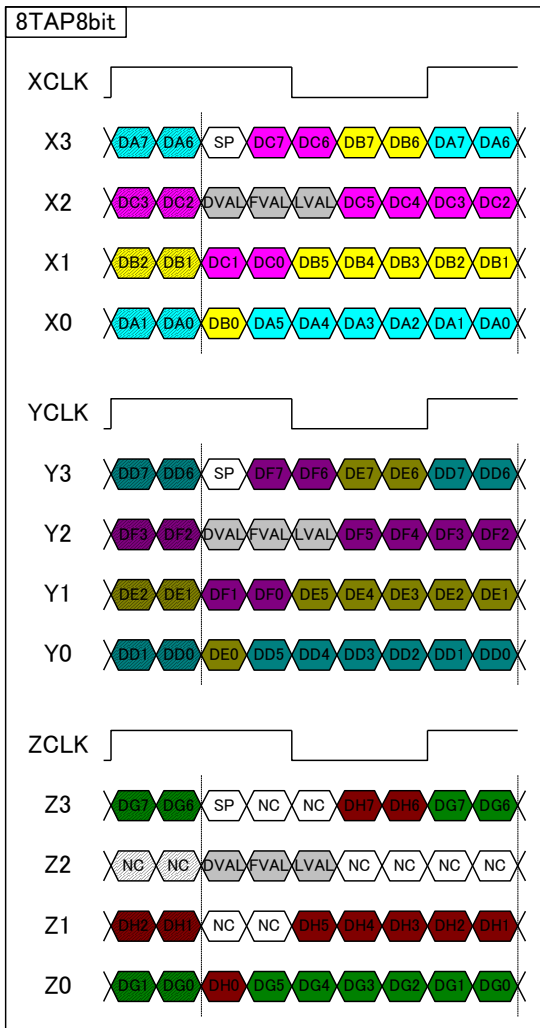

DA0 to DA7: 8bit data for one pixel from TAP1
 DB0 to DB7: 8bit data for one pixel from TAP2
 DC0 to DC7: 8bit data for one pixel from TAP3
 DD0 to DD7: 8bit data for one pixel from TAP4
 DE0 to DE7: 8bit data for one pixel from TAP5
 DF0 to DF7: 8bit data for one pixel from TAP6
 DG0 to DG7: 8bit data for one pixel from TAP7
 DH0 to DH7: 8bit data for one pixel from TAP8

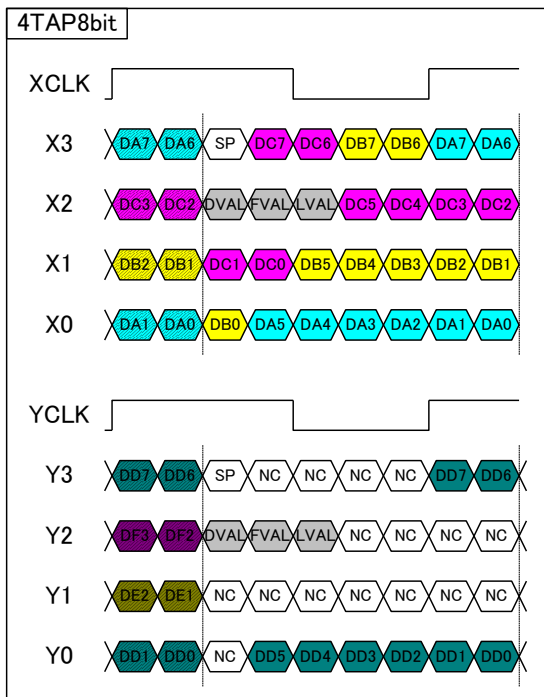

DA0 to DA7: 8bit data for one pixel from TAP1
 DB0 to DB7: 8bit data for one pixel from TAP2
 DC0 to DC7: 8bit data for one pixel from TAP3
 DD0 to DD7: 8bit data for one pixel from TAP4

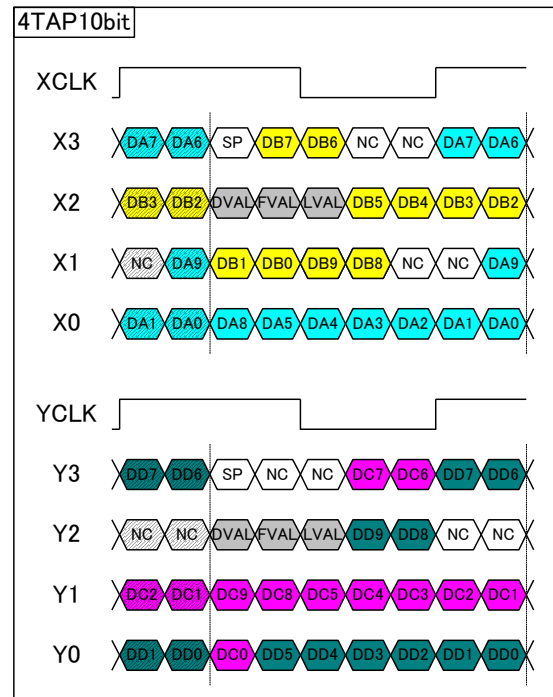

DA0 to DA9: 10bit data for one pixel from TAP1
 DB0 to DB9: 10bit data for one pixel from TAP2
 DC0 to DC9: 10bit data for one pixel from TAP3
 DD0 to DD9: 10bit data for one pixel from TAP4

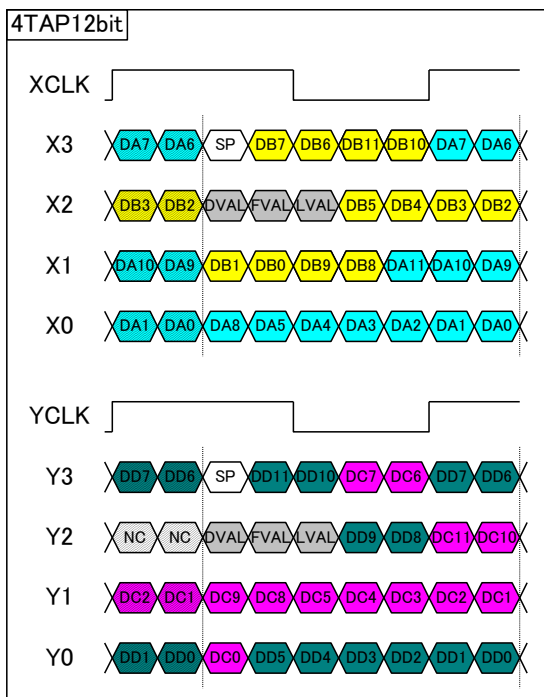

DA0 to DA11: 10bit data for one pixel from TAP1
 DB0 to DB11: 10bit data for one pixel from TAP2
 DC0 to DC11: 10bit data for one pixel from TAP3
 DD0 to DD11: 10bit data for one pixel from TAP4

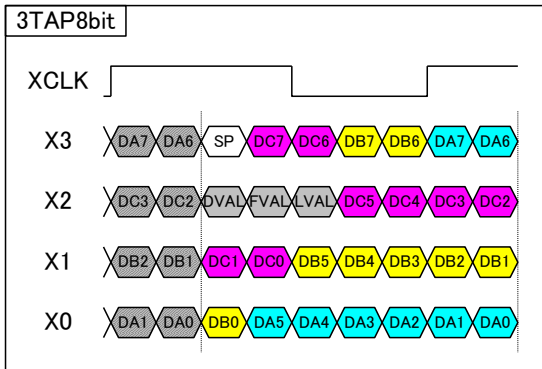

DA0 to DA7: 8bit data for one pixel from TAP1
 DB0 to DB7: 8bit data for one pixel from TAP2
 DC0 to DC7: 8bit data for one pixel from TAP3

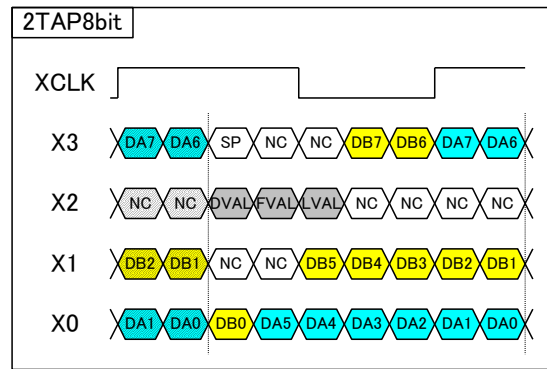

DA0 to DA7: 8bit data for one pixel from TAP1
 DB0 to DB7: 8bit data for one pixel from TAP2

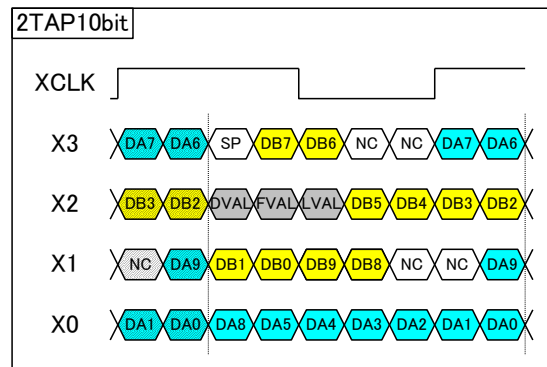

DA0 to DA9: 10bit data for one pixel from TAP1
 DB0 to DB9: 10bit data for one pixel from TAP2

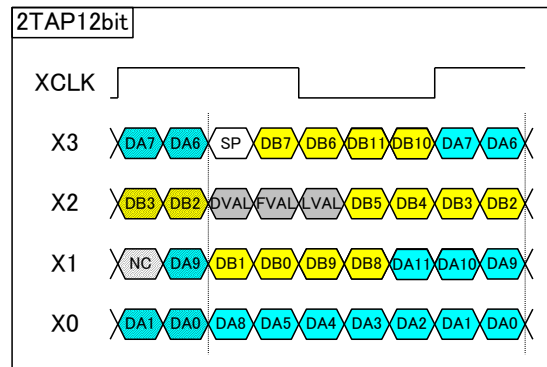

DA0 to DA11: 12bit data for one pixel from TAP1
 DB0 to DB11: 12bit data for one pixel from TAP2

4.6 Camera Link TAP Geometry

4.6.1 10TAP (1X10-1Y)

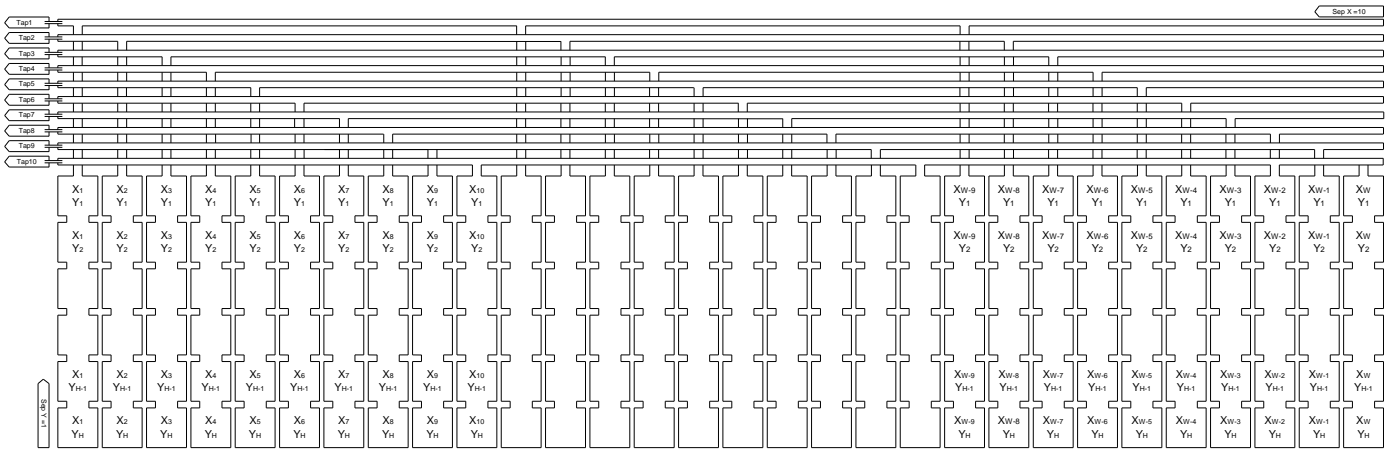

4.6.2 8TAP (1X8-1Y)

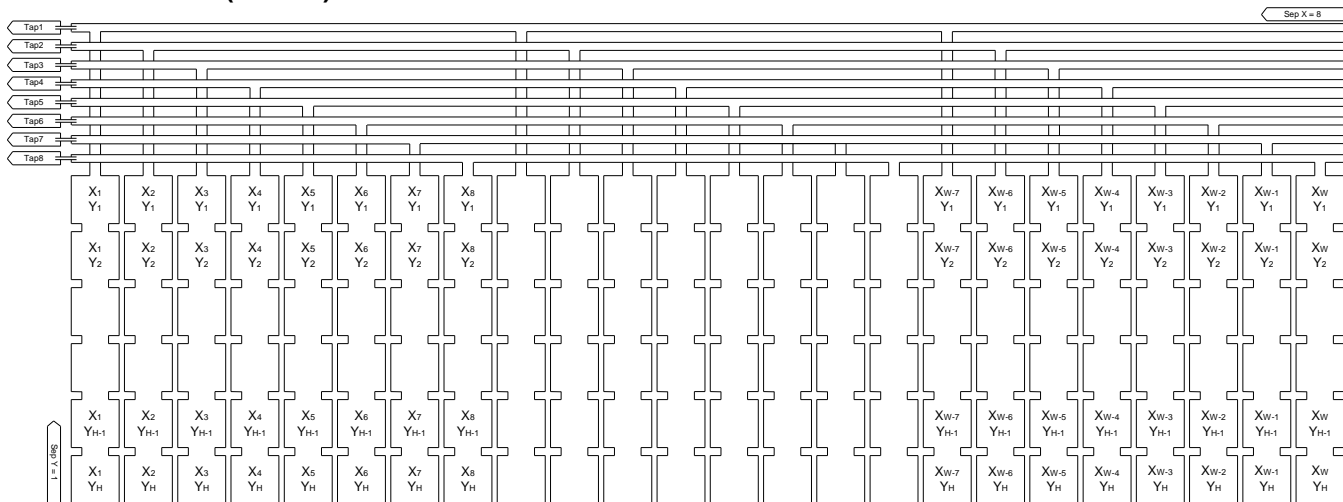

4.6.3 4TAP (1X4-1Y)

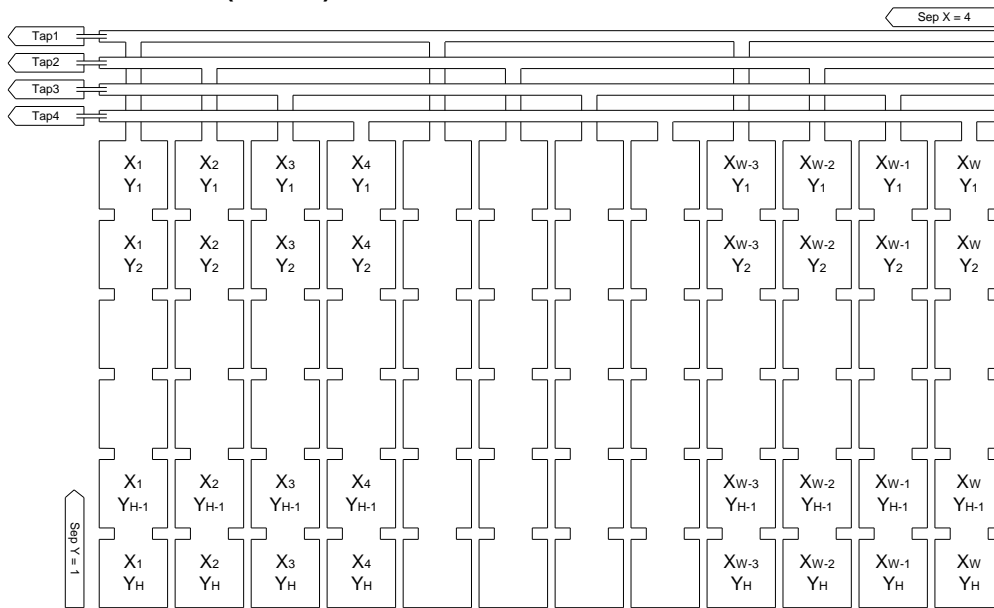

4.6.4 2TAP (1X2-1Y)

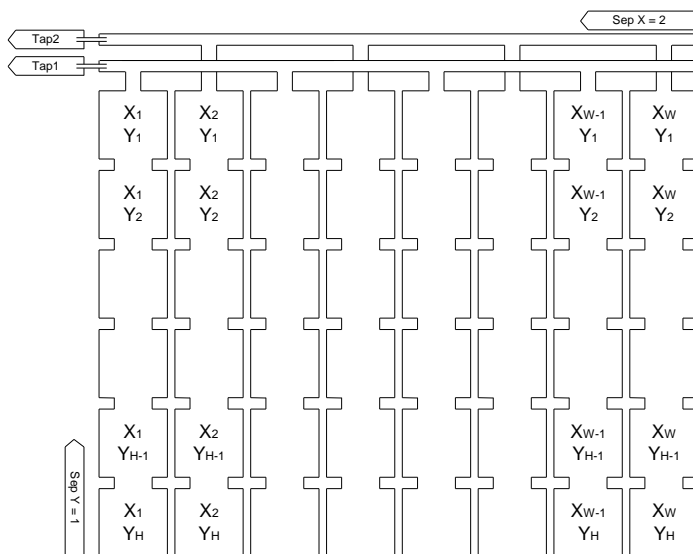

4.7 Bayer Pattern for Color Model (STC-CMC120APCL)

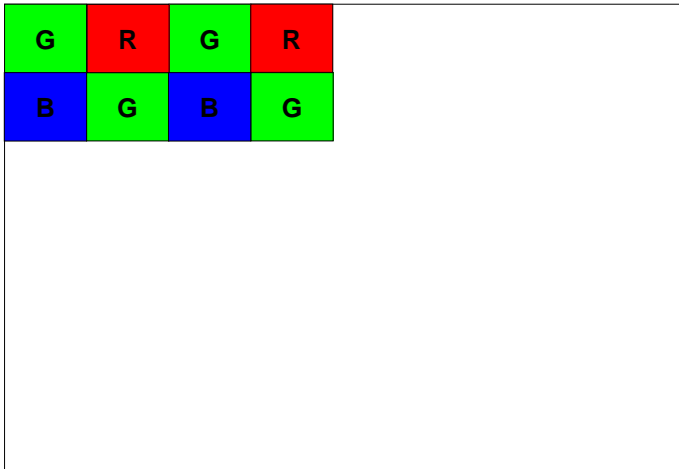

5 Camera Function Modes

5.1 Normal Mode

5.1.1 Normal Mode (Electronic shutter)

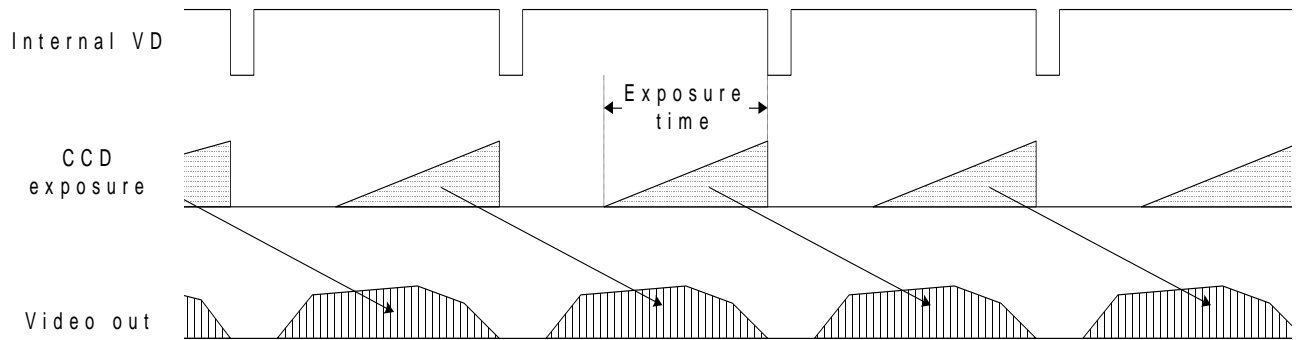

5.2 Pulse Width Trigger Mode

In this trigger mode with positive polarity, the camera exposure starts at the rising edge of the trigger pulse and stops at the falling edge of the trigger pulse. Therefore, when the exposure positive polarity is selected, the exposure periods are the high states of the trigger pulse.

5.2.1 Pulse Width Trigger Mode

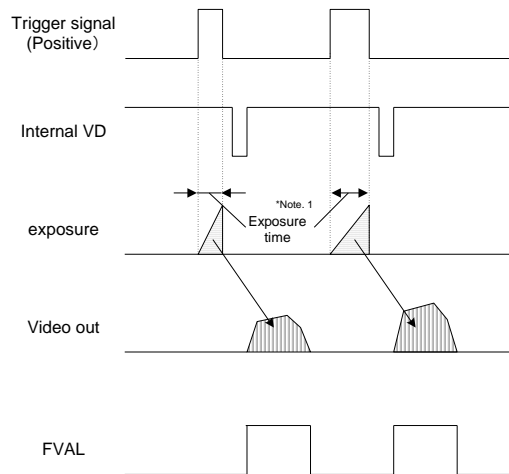

Note.1: The exposure time is set by the pulse width of the trigger signal. There is no FVAL output without any trigger signal.

5.2.2 Pulse Width Trigger Mode (Exposure Timing)

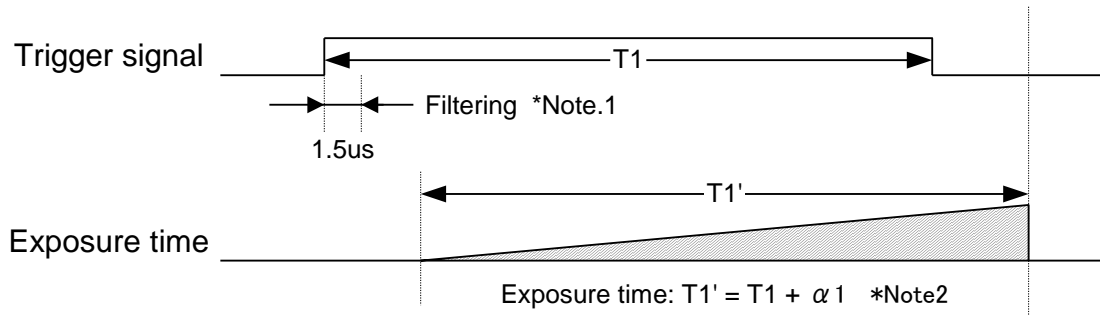

Note.1: The trigger signal is removed by the filter if the pulse width of the input trigger signal is less than 1.5us.
Please input the trigger signal with more than 1.5 us pulse width.

Note.2: $\alpha 1$ (Exposure time offset) is.

10,8,4,2TAP

41[us] (Edge Preset and Variable at Line unit)

42[us] (Pulse Width and Variable at us unit)

3TAP

42[us] (Edge Preset and Variable at Line unit)

43[us] (Pulse Width and Variable at us unit)

5.3 Edge Preset Trigger Mode

In this trigger mode, the camera exposure starts at the rising edge of the trigger pulse or negative edge when the setting is “Trigger Polarity::Negative”, the camera exposure starts at the falling edge of the trigger pulse. Exposure duration time is preset by the “Electrical Shutter” settings.

5.3.1 Edge Preset Trigger Mode

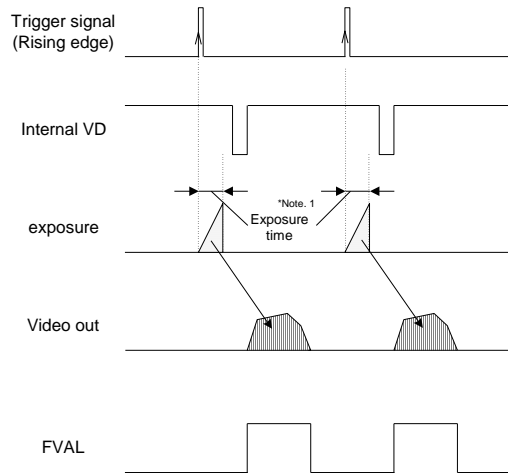

Note.1: The exposure time is set by the preset electronic shutter speed.

5.3.2 Edge Preset Trigger Mode (Exposure timing)

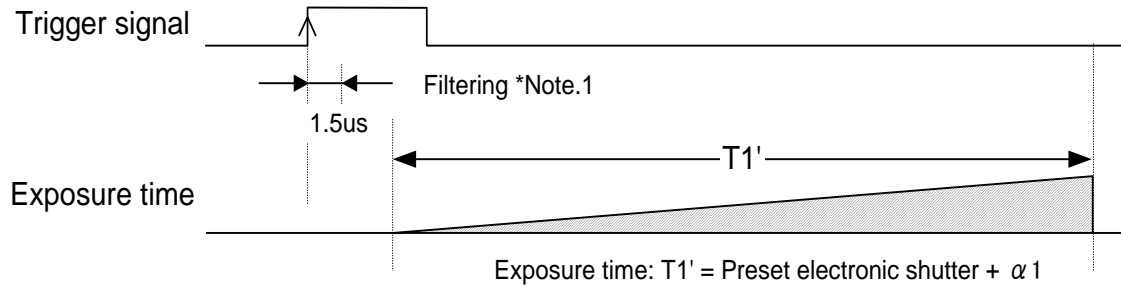

Note.1: The trigger signal is removed by the filter if the pulse width of the input trigger signal is less than 1.5us. Please input the trigger signal with more than 1.5 us pulse width.

Note.2: $\alpha 1$ (Exposure time offset) is.

10,8,4,2TAP

41[us] (Edge Preset and Variable at Line unit)

42[us] (Pulse Width and Variable at us unit)

3TAP

42[us] (Edge Preset and Variable at Line unit)

43[us] (Pulse Width and Variable at us unit)

6 Communication Protocol Specifications

This camera has communication function that enables external devices such as a PC to control the camera functions. Please use the "CLCtrl2 (Version1.01 or later)" communication software or use the following the communication protocol to communicate to the camera.

Note.

A communication problem may occur under the following conditions:

1. When the external sync frequency is incorrect (more than 1% off from the specified frequency).
2. When external sync is unstable (i.e bad external sync signal).
3. Approx. one second after switching from/to external sync mode to/from internal sync mode.
4. Approx. one second after switching frame rate.

6.1 Communication Method

UART (RS232C), Binary communication

6.2 Communication Settings

	Settings
Baud rate	9,600bps / 38,400bps / 57,600bps / 115,200bps
Data bit	8bit
Parity	None
Stop bit	1bit
Flow control	None

6.3 Communication Format

A. The format for sending data from the PC to the camera is as follows:

a. Send the read command

SOF (8bit)	Device code (6bit)	Read (1bit)	Page selection (1bit)	Command code (8bit)	Data length (8bit)	Data (1byte)	EOF (8bit)
---------------	-----------------------	----------------	--------------------------	------------------------	-----------------------	-----------------	---------------

b. Send the write command

SOF (8bit)	Device code (6bit)	Write (1bit)	Page selection (1bit)	Command code (8bit)	Data length (8bit)	Data (Data length byte)	EOF (8bit)
---------------	-----------------------	-----------------	--------------------------	------------------------	-----------------------	----------------------------	---------------

B. The format for receiving the data from the camera is as follows:

a. After the read command has been sent:

SOF (8bit)	Data length (8bit)	Data (Data length byte)	EOF (8bit)
---------------	-----------------------	----------------------------	---------------

b. After the write command has been sent:

SOF (8bit)	Data length (8bit) "00"	Receiving code (8bit)	EOF (8bit)
---------------	----------------------------	--------------------------	---------------

C. Descriptions of the format

Name	Descriptions				
SOF	Start of the frame Sets (or gets) the value is as "02H" always.				
Device code	Sets the device code of the camera is as "000000".				
Read / Write	Sets (or gets) "0" when send read command. Sets (or gets) "1" when send write command.				
Page selection	Sets "0" when access to the command register of the camera Gets current data from the command register when sent read command. The data of the command register is replaced by the sent data when sent write command. The data of the EEPROM is not replaced. Sets "1" when access to the EEPROM of the camera The camera works with the data of the EEPROM when the power on the camera. Gets the data from the EEPROM when sent read. The data of the EEPROM is replaced by sent data when sent write command. The camera sends the receiving coce as "01H" to the PC after the data of the EEPROM is replaced. The camera rejects other commands while the data of the EEPROM is being replaced (approximately 5 msec. / byte).				
Command code	Please refer from the following page.				
Data length	Data length (Unit: byte) Receiving data The data length is depending on the command after sent read command. The data length is "00H" after sent write command. Sending data The data length is 1 byte when send read command. The data length is depending on the command when send write command.				
Data	The value of the data is depending on the command				
EOF	End of the frame Sets (or gets) the value is as "03H" always				
Receiving code	Result of the sending command <table border="1" style="width: 100%; border-collapse: collapse;"> <tr> <td style="width: 50%;">01H: OK (ACK),</td> <td style="width: 50%;">10H: Receiving problem (NAC),</td> </tr> <tr> <td>11H: Communication problem</td> <td>14H: TimeOut</td> </tr> </table>	01H: OK (ACK),	10H: Receiving problem (NAC),	11H: Communication problem	14H: TimeOut
01H: OK (ACK),	10H: Receiving problem (NAC),				
11H: Communication problem	14H: TimeOut				

D. Example command

Send the read command to read the 00H address data of the register

02, 00, 00, 01, 00, 03

SOF, (Device code/Read/Register), Command code, Data length, Data, EOF

The return command

02, 01, 00, 03

6.4 Camera Control Commands

6.4.1 Camera Commands List (Device Code:00H)

Note. 1: The data unit of the each command is 1byte (8bit).

Note. 2: The data can be saved to the EEPROM if there is an “x” in the “Save to EEPROM” column in the list.
The camera is operating with the data of the EEPROM when the camera is powered on.

Command No.	Read /Write	Save to EEPROM	Function	Initial Data	Data Range
09-0FH			Reserved	-	
10H	R/W	O	The camera function mode 1 (8bit: D[7..0])	1	
11H	R/W	O	The camera function mode 2 (8bit: D[7..0])	08H	
12H	R/W	O	The camera function mode 3 (8bit: D[7..0])	50H	
13H			Reserved	-	
14H	R/W	O	The communication mode (8bit: D[7..0])	0	
15-1FH			Reserved	-	
20H	R/W	O	The exposure time of the electronic shutter (16bit: D[7..0])	1.536	0 to 16,777,215
21H	R/W	O	The exposure time of the electronic shutter (16bit: D[15..8])		
22H	R/W	O	The exposure time of the electronic shutter (16bit: D[23..16])		
23-27H			Reserved	-	
28H	R/W	O	The delay time for the trigger (8bit: D[7..0])	0	0 to 255
29-30H			Reserved	-	-
31H	R/W	O	The digital gain (8bit: D[7..0])	0	-
32-37H			Reserved	-	
38H	R/W	O	The clamp level (8bit: D[7..0])	40	0 to 80
39H			Reserved	-	-
3AH	R/W	O	White Balance R gain (8bit: D[7..0])	0	0 to 255
3BH	R/W	O	White Balance B gain (8bit: D[7..0])	0	0 to 255
3CH	R/W	O	White Balance Gr gain (8bit: D[7..0])	0	0 to 255
3DH	R/W	O	White Balance Gb gain (8bit: D[7..0])	0	0 to 255
3E-46H			Reserved	-	
47H	R/W	O	HDR / Number of Slopes	1	
48-4AH			Reserved	-	
4BH	R/W	O	PGA (8bit: D[7..0])	0	
4CH	R/W	O	Configurable DVAL Horizontal start pixel(16bit:D[7..0])	0	
4DH	R/W	O	Configurable DVAL Horizontal start pixel(16bit:D[15..8])		
4E-55H			Reserved	-	
56H	R/W	O	Knee1 Point	1	
57H	R/W	O	Knee2 Point	1	
58-67H			Reserved	-	
68H	R/W	O	Horizontal Flip	0	
78H	R/W	O	Test Pattern (8bit: D[7..0])	0	
79H	R/W	O	Image effect selection (8bit: D[7..0])	0	
7A-7FH			Reserved	-	
80H	R/W	O	EEPROM Control (8bit: D[7..0])	0	0 or 1
81H	R/W	O	Factory Default Load (8bit: D[7..0])	0	0 or 170
82-8FH			Reserved	-	

Command No.	Read /Write	Save to EEPROM	Function	Initial Data	Data Range
90H	R/W	0	The start line of the variable partial scanning A (16bit: D[7..0])	0	0 to 3,068
91H	R/W	0	The start line of the variable partial scanning A (16bit: D[15..8])		
92H	R/W	0	The start line of the variable partial scanning B (16bit: D[7..0])	0	0 to 3,068
93H	R/W	0	The start line of the variable partial scanning B (16bit: D[15..8])		
94H	R/W	0	The start line of the variable partial scanning C (16bit: D[7..0])	0	0 to 3,068
95H	R/W	0	The start line of the variable partial scanning C (16bit: D[15..8])		
96H	R/W	0	The start line of the variable partial scanning D (16bit: D[7..0])	0	0 to 3,068
97H	R/W	0	The start line of the variable partial scanning D (16bit: D[15..8])		
98H	R/W	0	The start line of the variable partial scanning E (16bit: D[7..0])	0	0 to 3,068
99H	R/W	0	The start line of the variable partial scanning E (16bit: D[15..8])		
9AH	R/W	0	The start line of the variable partial scanning F (16bit: D[7..0])	0	0 to 3,068
9BH	R/W	0	The start line of the variable partial scanning F (16bit: D[15..8])		
9CH	R/W	0	The start line of the variable partial scanning G (16bit: D[7..0])	0	0 to 3,068
9DH	R/W	0	The start line of the variable partial scanning G (16bit: D[15..8])		
9EH	R/W	0	The start line of the variable partial scanning H (16bit: D[7..0])	0	0 to 3,068
9FH	R/W	0	The start line of the variable partial scanning H (16bit: D[15..8])		
A0H	R/W	0	The effective lines of the variable partial scanning A (16bit: D[7..0])	3072	0 to 3072
A1H	R/W	0	The effective lines of the variable partial scanning A (16bit: D[15..8])		
A2H	R/W	0	The effective lines of the variable partial scanning B (16bit: D[7..0])	0	0 to 3072
A3H	R/W	0	The effective lines of the variable partial scanning B (16bit: D[15..8])		
A4H	R/W	0	The effective lines of the variable partial scanning C (16bit: D[7..0])	0	0 to 3072
A5H	R/W	0	The effective lines of the variable partial scanning C (16bit: D[15..8])		
A6H	R/W	0	The effective lines of the variable partial scanning D (16bit: D[7..0])	0	0 to 3072
A7H	R/W	0	The effective lines of the variable partial scanning D (16bit: D[15..8])		
A8H	R/W	0	The effective lines of the variable partial scanning E (16bit: D[7..0])	0	0 to 3072
A9H	R/W	0	The effective lines of the variable partial scanning E (16bit: D[15..8])		
AAH	R/W	0	The effective lines of the variable partial scanning F (16bit: D[7..0])	0	0 to 3072
ABH	R/W	0	The effective lines of the variable partial scanning F (16bit: D[15..8])		
ACH	R/W	0	The effective lines of the variable partial scanning G (16bit: D[7..0])	0	0 to 3072
ADH	R/W	0	The effective lines of the variable partial scanning G (16bit: D[15..8])		
AEH	R/W	0	The effective lines of the variable partial scanning H (16bit: D[7..0])	0	0 to 3072
AFH	R/W	0	The effective lines of the variable partial scanning H (16bit: D[15..8])		

Command No.	Read /Write	Save to EEPROM	Function	Initial Data	Data Range
B0H	R/W	O	The start Pixel of the variable partial scanning A (16bit: D[7..0])	0	0 to 4095
B1H	R/W	O	The start Pixel of the variable partial scanning A (16bit: D[15..8])		
B2H	R/W	O	The start Pixel of the variable partial scanning B (16bit: D[7..0])	0	0 to 4095
B3H	R/W	O	The start Pixel of the variable partial scanning B (16bit: D[15..8])		
B4H	R/W	O	The start Pixel of the variable partial scanning C (16bit: D[7..0])	0	0 to 4095
B5H	R/W	O	The start Pixel of the variable partial scanning C (16bit: D[15..8])		
B6H	R/W	O	The start Pixel of the variable partial scanning D (16bit: D[7..0])	0	0 to 4095
B7H	R/W	O	The start Pixel of the variable partial scanning D (16bit: D[15..8])		
B8H	R/W	O	The start Pixel of the variable partial scanning E (16bit: D[7..0])	0	0 to 4095
B9H	R/W	O	The start Pixel of the variable partial scanning E (16bit: D[15..8])		
BAH	R/W	O	The start Pixel of the variable partial scanning F (16bit: D[7..0])	0	0 to 4095
BBH	R/W	O	The start Pixel of the variable partial scanning F (16bit: D[15..8])		
BCH	R/W	O	The start Pixel of the variable partial scanning G (16bit: D[7..0])	0	0 to 4095
BDH	R/W	O	The start Pixel of the variable partial scanning G (16bit: D[15..8])		
BEH	R/W	O	The start Pixel of the variable partial scanning H (16bit: D[7..0])	0	0 to 4095
BFH	R/W	O	The start Pixel of the variable partial scanning H (16bit: D[15..8])		
C0H	R/W	O	The effective Pixel of the variable partial scanning A (16bit: D[7..0])	4096	0 to 4096
C1H	R/W	O	The effective Pixel of the variable partial scanning A (16bit: D[15..8])		
C2H	R/W	O	The effective Pixel of the variable partial scanning B (16bit: D[7..0])	0	0 to 4096
C3H	R/W	O	The effective Pixel of the variable partial scanning B (16bit: D[15..8])		
C4H	R/W	O	The effective Pixel of the variable partial scanning C (16bit: D[7..0])	0	0 to 4096
C5H	R/W	O	The effective Pixel of the variable partial scanning C (16bit: D[15..8])		
C6H	R/W	O	The effective Pixel of the variable partial scanning D (16bit: D[7..0])	0	0 to 4096
C7H	R/W	O	The effective Pixel of the variable partial scanning D (16bit: D[15..8])		
C8H	R/W	O	The effective Pixel of the variable partial scanning E (16bit: D[7..0])	0	0 to 4096
C9H	R/W	O	The effective Pixel of the variable partial scanning E (16bit: D[15..8])		
CAH	R/W	O	The effective Pixel of the variable partial scanning F (16bit: D[7..0])	0	0 to 4096
CBH	R/W	O	The effective Pixel of the variable partial scanning F (16bit: D[15..8])		
CCH	R/W	O	The effective Pixel of the variable partial scanning G (16bit: D[7..0])	0	0 to 4096
CDH	R/W	O	The effective Pixel of the variable partial scanning G (16bit: D[15..8])		
CEH	R/W	O	The effective Pixel of the variable partial scanning H (16bit: D[7..0])	0	0 to 4096
CFH	R/W	O	The effective Pixel of the variable partial scanning H (16bit: D[15..8])		
D0-DDH			Reserved	-	
DEH	R/W	O	Pixel Blemish Correction Mode1 (8bit: D[7..0])	1	
DFH	R/W	O	Pixel Blemish Correction Mode2 (8bit: D[15..8])	70H	
E0-E2H			Reserved	-	
E3H			FPN Correction Mode (8bit: D[7..0])	17	0 or 17
E4-EDH			Reserved	-	
EEH			Camera Operation Mode (16bit: D[7..0])	3	3
EFH			Camera Operation Mode (16bit: D[15..8])		
F0-FFH			Reserved		

6.4.2 Description of the Camera Control Commands

(The underlined settings are the factory default settings)

Command No.	Command Descriptions								
10H: MOD1[7..0]	<p>[The camera function mode 1] Initial data: MOD1[7..0] = 01H This command sets the camera function mode. D[7..0]</p> <table border="1"> <tr> <td>D7</td><td>D6</td><td>D5</td><td>D4</td><td>D3</td><td>D2</td><td>D1</td><td>D0</td> </tr> </table> <p>D7: No function Always set as "0" D6: Trigger polarity <u>0: Positive</u> 1: Negative D5: Trigger mode <u>0: Edge preset</u> 1: Pulse width D4 to D1: No function Always set as "0000" D0: Exposure time unit <u>0: Line Unit</u> <u>1: usec Unit</u></p>	D7	D6	D5	D4	D3	D2	D1	D0
D7	D6	D5	D4	D3	D2	D1	D0		
11H: MOD2[7..0]	<p>[The camera function mode 2] Initial data : MOD2[7..0] = 08H This command sets the camera function mode. D[7..0]</p> <table border="1"> <tr> <td>D7</td><td>D6</td><td>D5</td><td>D4</td><td>D3</td><td>D2</td><td>D1</td><td>D0</td> </tr> </table> <p>D7: No function Always set as "0" D6 to D5: No function <u>00: 85MHz</u> 10: 42.5MHz 01,11: No function (Prohibited setting. Do not set these values) D4: No function Always set as "0" D3: Function mode <u>0: Trigger mode</u> <u>1: Continuous mode</u> D2 to D0: No function Always set as "000" * There is no video output without the trigger signal input while the camera runs in trigger mode.</p>	D7	D6	D5	D4	D3	D2	D1	D0
D7	D6	D5	D4	D3	D2	D1	D0		
12H: MOD3[7..0]	<p>[The camera function mode 3] Initial data: MOD3[7..0] = 50H This command sets the camera function mode. D[7..0]</p> <table border="1"> <tr> <td>D7</td><td>D6</td><td>D5</td><td>D4</td><td>D3</td><td>D2</td><td>D1</td><td>D0</td> </tr> </table> <p>D7 to D6 Video out <u>00: 10bit</u> <u>01: 8bit</u> 10: 12bit , *12H 11: No function D5: Trigger signal input connector <u>0: Camera Link (CC1)</u> 1: Power/IO connector(No. 2 pin, SP4) D4: Exposure start mode <u>0: Normal</u> <u>1: Horizontal Synchronization</u> D3 to D0: No function Always set as "000"</p>	D7	D6	D5	D4	D3	D2	D1	D0
D7	D6	D5	D4	D3	D2	D1	D0		
14H: UART [7..0]	<p>[The communication mode] Initial data: UART[7..0] = 01H This command sets the communication mode. D[7..0]</p> <table border="1"> <tr> <td>D7</td><td>D6</td><td>D5</td><td>D4</td><td>D3</td><td>D2</td><td>D1</td><td>D0</td> </tr> </table> <p>D7 to D2 No function Always set as "000000" D1 to D0: Communication mode <u>00: 38,400bps</u> <u>01: 9600bps</u> 10: 57,600 11: 115,200bps</p>	D7	D6	D5	D4	D3	D2	D1	D0
D7	D6	D5	D4	D3	D2	D1	D0		

Command No.	Command Descriptions								
20H: SVR[7..0] 21H: SVR[15..8] 22H: SVR[23..16]	<p>[The exposure time of the electronic shutter] Initial data: SVR[23..0] = 1,536, Range: 0 to 16,777,215 This command sets the preset shutter speed for electronic shutter.</p> <p>D[7..0]</p> <table border="1" style="margin-left: 20px;"> <tr> <td>D7</td><td>D6</td><td>D5</td><td>D4</td><td>D3</td><td>D2</td><td>D1</td><td>D0</td> </tr> </table> <p>Case 10h.0 =0 (Exposure time on Usec unit)</p> <ul style="list-style-type: none"> • 10TAP Exposure time (shutter speed) = ((SVR[23..0] -1) x 258 + 1020) x 10 / 250 x 10⁶ Unit: usec • 8,4,2TAP Exposure time (shutter speed) = ((SVR[23..0]-1) X 258 + 851) x 10 / 250 x 10⁶ Unit: usec <p>*Minimum shutter speed with Pulse Width Trigger on Line unit is up to 41useconds</p> <ul style="list-style-type: none"> • 3TAP Exposure time (shutter speed) = ((SVR[23..0]-1) X 258 + 647) x 10 / 187.5 x 10⁶ Unit: usec <p>*Minimum shutter speed with Pulse Width Trigger on Line unit is up to 42useconds</p> <p>10h.0=1 (Exposure time on Usec unit)</p> <p>Exposure time (shutter speed) = 1 X SVR[] Unit: usec</p> <p>*Minimum shutter speed on Usec unit is</p> <p>10,8,4,2TAP up to 42useconds</p> <p>3TAP up to 43useconds</p>	D7	D6	D5	D4	D3	D2	D1	D0
D7	D6	D5	D4	D3	D2	D1	D0		
28H: DLY[7..0]	<p>[The delay time for the trigger] Initial data: : DLY[7..0] = 0、 Range: 0 to 255 This command sets the delay time that occurs from the trigger signal input to start exposure. Delay time = 2us X DLY[7..0] (useconds)</p>								
31H: DGB[7..0]	<p>[The digital gain] Initial data: DGB[7..0] = 0 Video level = (Input video level - CLAMP[7..0]) X (1 + DGB[7..0] / 64) + CLAMP[7..0] CLAMP[7..0] : The clamp level (The value of the address 38H)</p>								
38H: CLAMP[7..0]	<p>[The clamp level] Initial data: CLAMP[7..0] = 40、 Range: : 0 to 80 This command sets the clamp level (The clamp level of the black signal). This value is as 10bit video image. When 8bit is selected, clamp level should be 1/4 of setting value.</p>								
3AH: WBR[7..0]	<p>[White Blance R Gain] Initial data: WBR[7..0] = 0、 Range: 0to255 This command sets the Red gain on Bayer. Video level = (Input video level - CLAMP[7..0]) X (1 + WBR[7..0] / 64) + CLAMP[7..0]</p>								
3BH: WBB[7..0]	<p>[White Blance B Gain] Initial data: WBB[7..0] = 0、 Range: 0to255 This command sets the Blue gain on Bayer. Video level = (Input video level - CLAMP[7..0]) X (1 + WBB[7..0] / 64) + CLAMP[7..0]</p>								
3CH: WBGR[7..0]	<p>[White Blance GR Gain] Initial data: WBGR[7..0] = 0、 Range: 0to255 This command sets the Green gain on Bayer GR line. Video level = (Input video level - CLAMP[7..0]) X (1 + WBGR[7..0] / 64) + CLAMP[7..0]</p>								
3DH: WBGB[7..0]	<p>[White Blance GB Gain] Initial data: WBGB[7..0] = 0、 Range: 0to255 This command sets the Green gain on Bayer GB line. Video level = (Input video level - CLAMP[7..0]) X (1 + WBGB[7..0] / 64) + CLAMP[7..0]</p>								

Command No.	Command Descriptions								
47H: HDR[7..0]	<p>[HDR] Initial data: HDR[7..0] = 1 This command sets the Slope number on HDR. D[7..0]</p> <table border="1"> <tr> <td>D7</td><td>D6</td><td>D5</td><td>D4</td><td>D3</td><td>D2</td><td>D1</td><td>D0</td> </tr> </table> <p>D7 to D6: HDR Mode <u>0:Disable,</u> 3:Enable D5 to D2: No function Always set as "0000" D1 to D0: Number of Slopes 0 : No function 1 : No function <u>2 : 2 Slopes</u> 3 : 3 Slopes</p>	D7	D6	D5	D4	D3	D2	D1	D0
D7	D6	D5	D4	D3	D2	D1	D0		
4BH: PGA[7..0]	<p>[PGA] Initial data: PGA[7..0] = 0 This command sets the gain in order to adjust the brightness. D[7..0]</p> <table border="1"> <tr> <td>D7</td><td>D6</td><td>D5</td><td>D4</td><td>D3</td><td>D2</td><td>D1</td><td>D0</td> </tr> </table> <p>D7: No function <u>Always set as "0"</u> D6 to D5: PGA Gain <u>0:x1.0 gain</u> 1:x1.2 gain 3:x1.4 gain 4:x1.6 gain D4 to D0: No function <u>Always set as "00000"</u></p>	D7	D6	D5	D4	D3	D2	D1	D0
D7	D6	D5	D4	D3	D2	D1	D0		
56H: KN1P [7..0]	<p>[Knee1 parameter] Initial data: KN1P[7..0] = 1 This command sets the exposure time for the electronic shutter for the knee1 point, and also for the exposure time. HDR[7..0] : 47H should be set 2 Slopes or 3 Slopes Knee1 Exp = EXPTA[23..0] X KN1P[7..0] / 256 ※EXPTA[23..0]:22Hto20H</p>								
57H: KN2P [7..0]	<p>[Knee2] Initial data: KN2P [7..0] = 1, Range: 0 to 255 This command sets the exposure time for the electronic shutter for the knee2 point, and also for the exposure time. Parameter should be set as % of exposure time. HDR[7..0] : 47H should be set 3 Slopes Knee2 Exp = EXPTA[23..0] X KN1P[7..0] / 256 ※EXPTA[23..0]:22Hto20H</p>								
5BH: Vlow2 [7..0]	<p>[Vlow2] Initial data: Vlow2 [7..0] = 96, Range: 0 to 255 This command sets the Vlow2 voltage for the HDR saturation level voltage. HDR[7..0] : 47H should be set 2 Slopes or 3 Slopes</p>								
5CH: Vlow3 [7..0]	<p>[Vlow3] Initial data: Vlow2 [7..0] = 96, Range: : 0 to 255 This command sets the Vlow3 voltage for the HDR saturation level voltage. HDR[7..0] : 47H should be set 3 Slopes</p>								
68H: [7..0]	<p>[Reverse mode] Initial data: [7..0] = 0 This command sets the image output direction. D[7..0]</p> <table border="1"> <tr> <td>D7</td><td>D6</td><td>D5</td><td>D4</td><td>D3</td><td>D2</td><td>D1</td><td>D0</td> </tr> </table> <p>D7 to D6: No Function Always set as "00" D5: Vertical mirror image <u>0: Normal image</u> 1: Vertical mirror image D4: Horizontal mirror image <u>0: Normal image</u> 1:Horizontal mirror image D3 to D0: No Function Always set as "0000"</p>	D7	D6	D5	D4	D3	D2	D1	D0
D7	D6	D5	D4	D3	D2	D1	D0		

Command No.	Command Descriptions								
78H: TESTP[7..0]	[Test Pattern] Initial data: TESTP [7..0] = 00H This command sets the test pattern video output. D[7..0] <table border="1" style="margin-left: 40px;"> <tr> <td>D7</td><td>D6</td><td>D5</td><td>D4</td><td>D3</td><td>D2</td><td>D1</td><td>D0</td></tr> </table> <div style="display: flex; justify-content: space-between; margin-left: 40px;"> <div> <p><u>0: Normal Video Image</u></p> <p>2: Ramp</p> <p>4: White Clip</p> <p>Others: Black</p> </div> <div> <p>1: Gray Scale</p> <p>3: 100% White</p> <p>6: Color Bar(RGB BAYER)</p> </div> </div>	D7	D6	D5	D4	D3	D2	D1	D0
D7	D6	D5	D4	D3	D2	D1	D0		
79H: EFFCT[7..0]	[Image effect selection] Initial data: EFFCT[7..0] = 00H This command sets the image effect. Image data depends on the Tap number of the Camera Link output. If the value is not enough, the value will drop off. When the horizontal start pixel position is larger than the actual number, the horizontal start pixel position should be set to 0. D[7..0] <table border="1" style="margin-left: 40px;"> <tr> <td>D7</td><td>D6</td><td>D5</td><td>D4</td><td>D3</td><td>D2</td><td>D1</td><td>D0</td></tr> </table> <div style="display: flex; justify-content: space-between; margin-left: 40px;"> <div> <p>D7: Negative / Positive video selection</p> <p>D6 to D0: Image effect</p> </div> <div> <p><u>0: Positive image</u></p> <p><u>00H: No effect (Original)</u></p> <p>02H: 9bit gradation</p> <p>04H: 6bit gradation</p> <p>06H: 4bit gradation</p> <p>08H: 2bit gradation</p> <p>0A to 7FH: No Function (Prohibited settings. Do not set these values)</p> </div> <div> <p>1: Negative image</p> <p>01H: 9bit gradation</p> <p>03H: 7bit gradation</p> <p>05H: 5bit gradation</p> <p>07H: 3bit gradation</p> <p>09H: 1bit gradation</p> </div> </div>	D7	D6	D5	D4	D3	D2	D1	D0
D7	D6	D5	D4	D3	D2	D1	D0		
80H: E2P[7..0]	[EEPROM control] Initial data: E2P[7..0] = 0 D[7..0] <table border="1" style="margin-left: 40px;"> <tr> <td>D7</td><td>D6</td><td>D5</td><td>D4</td><td>D3</td><td>D2</td><td>D1</td><td>D0</td></tr> </table> <div style="display: flex; justify-content: space-between; margin-left: 40px;"> <div> <p>D7 to D1: No function</p> <p>D6 to D0: Write control to the EEPROM</p> </div> <div> <p><u>Always set as “0000000”</u></p> <p><u>0: Prohibited</u></p> </div> <div> <p>1: Accept</p> </div> </div> <p>Note: This bit is cleared to “0” automatically by the internal processes after the command is executed.</p>	D7	D6	D5	D4	D3	D2	D1	D0
D7	D6	D5	D4	D3	D2	D1	D0		
81H: INI[7..0]	[Reload camera default setting] Initial data: INI [7..0] = 00H This command sets the factory setting. D[7..0] <table border="1" style="margin-left: 40px;"> <tr> <td>D7</td><td>D6</td><td>D5</td><td>D4</td><td>D3</td><td>D2</td><td>D1</td><td>D0</td></tr> </table> <p>Note: Once the camera setting is reloaded, the register may set “0” automatically. This setting data does not save on the EEPROM through this register.</p> <div style="display: flex; justify-content: space-between; margin-left: 40px;"> <div> <p>D[7..0]: Factory Setting</p> </div> <div> <p><u>0: No Function</u></p> </div> <div> <p>170: Reload factory setting</p> </div> </div>	D7	D6	D5	D4	D3	D2	D1	D0
D7	D6	D5	D4	D3	D2	D1	D0		

Command No.	Command Descriptions
90H: VASA[7..0] 91H: VASA[15..8]	[Vertical AOI Start Line AOI_A] Initial data: : VASA[15..0] = 0、 Range: 0 to 3,068 This command sets the Vertical AOI Start Line AOI_A. The value should be set to 4 Lines each. (e.g. : 0、 4、 8、 to 3,068)
92H: VASB[7..0] 93H: VASB[15..8]	[Vertical AOI Start Line AOI_B] Initial data: : VASB[15..0] = 0、 Range: 0 to 3,068 This command sets the Vertical AOI Start Line AOI_B. This command sets the Vertical AOI Start Line AOI_A. The value should be set to 4 Lines each. (e.g. : 0、 4、 8、 to 3,068)
94H: VASC[7..0] 95H: VASC[15..8]	[Vertical AOI Start Line AOI_C] Initial data: : VASC[15..0] = 0、 Range: 0 to 3,068 This command sets the Vertical AOI Start Line AOI_C. This command sets the Vertical AOI Start Line AOI_A. The value should be set to 4 Lines each. (e.g. : 0、 4、 8、 to 3,068)
96H: VASD[7..0] 97H: VASD[15..8]	[Vertical AOI Start Line AOI_D] Initial data: : VASD[15..0] = 0、 Range: 0 to 3,068 This command sets the Vertical AOI Start Line AOI_D. This command sets the Vertical AOI Start Line AOI_A. The value should be set to 4 Lines each. (e.g. : 0、 4、 8、 to 3,068)
98H: VASE[7..0] 99H: VASE[15..8]	[Vertical AOI Start Line AOI_E] Initial data: : VASE[15..0] = 0、 Range: 0 to 3,068 This command sets the Vertical AOI Start Line AOI_E. This command sets the Vertical AOI Start Line AOI_A. The value should be set to 4 Lines each. (e.g. : 0、 4、 8、 to 3,068)
9AH: VASF[7..0] 9BH: VASF[15..8]	[Vertical AOI Start Line AOI_F] Initial data: : VASF[15..0] = 0、 Range: 0 to 3,068 This command sets the Vertical AOI Start Line AOI_F. This command sets the Vertical AOI Start Line AOI_A. The value should be set to 4 Lines each. (e.g. : 0、 4、 8、 to 3,068)
9CH: VASG[7..0] 9DH: VASG[15..8]	[Vertical AOI Start Line AOI_G] Initial data: : VASG[15..0] = 0、 Range: 0 to 3,068 This command sets the Vertical AOI Start Line AOI_G. This command sets the Vertical AOI Start Line AOI_A. The value should be set to 4 Lines each. (e.g. : 0、 4、 8、 to 3,068)
9EH: VASH[7..0] 9EH: VASH[15..8]	[Vertical AOI Start Line AOI_H] Initial data: : VASH[15..0] = 0、 Range: 0 to 3,068 This command sets the Vertical AOI Start Line AOI_H. This command sets the Vertical AOI Start Line AOI_A. The value should be set to 4 Lines each. (e.g. : 0、 4、 8、 to 3,068)

Command No.	Command Descriptions
A0H: VAHA[7..0] A1H: VAHA[15..8]	[Vertical AOI Effective Line AOI_A] Initial data: VAHA[15..0] = 3,072、 Range: 4 to 3,072 This command sets the number of the effective lines (image height) of the variable partial scanning. The value should be set to 4 Lines each. The camera works with full scanning, when the total effective lines of the eight partial. (VAHA [] + VAHB[] + VAHC[] + VAHD[] + VAHE[] + VAHF[] + VAHG[] + VAHH[]) is greater than 3072.
A2H: VAHB[7..0] A3H: VAHB[15..8]	[Vertical AOI Effective Line AOI_B] Initial data: VAHB[15..0] = 3,072、 Range: 4 to 3,072 This command sets the number of the effective lines (image height) of the variable partial scanning. The value should be set to 4 Lines each. The camera works with full scanning, when the total effective lines of the eight partial. (VAHA [] + VAHB[] + VAHC[] + VAHD[] + VAHE[] + VAHF[] + VAHG[] + VAHH[]) is greater than 3072.
A4H: VAHC[7..0] A5H: VAHC[15..8]	[Vertical AOI Effective Line AOI_C] Initial data: VAHC[15..0] = 3,072、 Range: 4 to 3,072 This command sets the number of the effective lines (image height) of the variable partial scanning. The value should be set to 4 Lines each. The camera works with full scanning, when the total effective lines of the eight partial. (VAHA [] + VAHB[] + VAHC[] + VAHD[] + VAHE[] + VAHF[] + VAHG[] + VAHH[]) is greater than 3072.
A6H: VAHD[7..0] A7H: VAHD[15..8]	[Vertical AOI Effective Line AOI_D] Initial data: VAHD[15..0] = 3,072、 Range: 4 to 3,072 This command sets the number of the effective lines (image height) of the variable partial scanning. The value should be set to 4 Lines each. The camera works with full scanning, when the total effective lines of the eight partial. (VAHA [] + VAHB[] + VAHC[] + VAHD[] + VAHE[] + VAHF[] + VAHG[] + VAHH[]) is greater than 3072.
A8H: VAHE[7..0] A9H: VAHE[15..8]	[Vertical AOI Effective Line AOI_E] Initial data: VAHE[15..0] = 3,072、 Range: 4 to 3,072 This command sets the number of the effective lines (image height) of the variable partial scanning. The value should be set to 4 Lines each. The camera works with full scanning, when the total effective lines of the eight partial. (VAHA [] + VAHB[] + VAHC[] + VAHD[] + VAHE[] + VAHF[] + VAHG[] + VAHH[]) is greater than 3072.
AAH: VAHF[7..0] ABH: VAHF[15..8]	[Vertical AOI Effective Line AOI_F] Initial data: VAHF[15..0] = 3,072、 Range: 4 to 3,072 This command sets the number of the effective lines (image height) of the variable partial scanning. The value should be set to 4 Lines each. The camera works with full scanning, when the total effective lines of the eight partial. (VAHA [] + VAHB[] + VAHC[] + VAHD[] + VAHE[] + VAHF[] + VAHG[] + VAHH[]) is greater than 3072.
ACH: VAHG[7..0] ADH: VAHG[15..8]	[Vertical AOI Effective Line AOI_G] Initial data: VAHG[15..0] = 3,072、 Range: 4 to 3,072 This command sets the number of the effective lines (image height) of the variable partial scanning. The value should be set to 4 Lines each. The camera works with full scanning, when the total effective lines of the eight partial. (VAHA [] + VAHB[] + VAHC[] + VAHD[] + VAHE[] + VAHF[] + VAHG[] + VAHH[]) is greater than 3072.
AEH: VAHH[7..0] AFH: VAHH[15..8]	[Vertical AOI Effective Line AOI_H] Initial data: VAHH[15..0] = 3,072、 Range: 4 to 3,072 This command sets the number of the effective lines (image height) of the variable partial scanning. The value should be set to 4 Lines each. The camera works with full scanning, when the total effective lines of the eight partial. (VAHA [] + VAHB[] + VAHC[] + VAHD[] + VAHE[] + VAHF[] + VAHG[] + VAHH[]) is greater than 3072.

Command No.	Command Descriptions
B0H: HASA[7..0] B1H: HASA[15..8]	[Horizontal AOI Start Pixel AOI_A] Initial data: HASA[15..0] = 0、 Range: 0 to 4,095 This command sets the Horizontal AOI Start Pixel AOI_A.
B2H: HASB[7..0] B3H: HASB[15..8]	[Horizontal AOI Start Pixel AOI_B] Initial data: HASB[15..0] = 0、 Range: 0 to 4,095 This command sets the Horizontal AOI Start Pixel AOI_B.
B4H: HASC[7..0] B5H: HASC[15..8]	[Horizontal AOI Start Pixel AOI_C] Initial data: HASC[15..0] = 0、 Range: 0 to 4,095 This command sets the Horizontal AOI Start Pixel AOI_C.
B6H: HASD[7..0] B7H: HASD[15..8]	[Horizontal AOI Start Pixel AOI_D] Initial data: HASD[15..0] = 0、 Range: 0 to 4,095 This command sets the Horizontal AOI Start Pixel AOI_D.
B8H: HASE[7..0] B9H: HASE[15..8]	[Horizontal AOI Start Pixel AOI_E] Initial data: HASE[15..0] = 0、 Range: 0 to 4,095 This command sets the Horizontal AOI Start Pixel AOI_E
BAH: HASF[7..0] BBH: HASF[15..8]	[Horizontal AOI Start Pixel AOI_F] Initial data: HASF[15..0] = 0、 Range: 0 to 4,095 This command sets the Horizontal AOI Start Pixel AOI_F.
BCH: HASG[7..0] BDH: HASG[15..8]	[Horizontal AOI Start Pixel AOI_G] Initial data: HASG[15..0] = 0、 Range: 0 to 4,095 This command sets the Horizontal AOI Start Pixel AOI_G.
BEH: HASH[7..0] BFH: HASH[15..8]	[Horizontal AOI Start Pixel AOI_H] Initial data: HASH[15..0] = 0、 Range: : 0 to 4,095 This command sets the Horizontal AOI Start Pixel AOI_H.

Command No.	Command Descriptions
C0H: HAWA[7..0] C1H: HAWA[15..8]	[Horizontal AOI Effective Pixel AOI_A] Initial data: HAWA[15..0] = 4,096、 Range: 0 to 4,096 This command sets the number of effective pixels (image width). The effective pixels are the same as DVAL. The variable value depends on the Tap number of Camera Link. When the effective pixels (image width) are 0 or larger than the horizontal pixels: Effective pixels (image width) = Horizontal pixels
C2H: HAWB[7..0] C3H: HAWB[15..8]	[Horizontal AOI Effective Pixel AOI_B] Initial data: HAWB[15..0] = 0、 Range: 0 to 4,096 This command sets the number of effective pixels (image width). The effective pixels are the same as DVAL. The variable value depends on the Tap number of Camera Link. When the effective pixels (image width) are 0 or larger than the horizontal pixels: Effective pixels (image width) = Horizontal pixels
C4H: HAWC[7..0] C5H: HAWC[15..8]	[Horizontal AOI Effective Pixel AOI_C] Initial data: HAWC[15..0] = 0、 Range: 0 to 4,096 This command sets the number of effective pixels (image width). The effective pixels are the same as DVAL. The variable value depends on the Tap number of Camera Link. When the effective pixels (image width) are 0 or larger than the horizontal pixels: Effective pixels (image width) = Horizontal pixels
C6H: HAWD[7..0] C7H: HAWD[15..8]	[Horizontal AOI Effective Pixel AOI_D] Initial data: HAWD[15..0] = 0、 Range: 0 to 4,096 This command sets the number of effective pixels (image width). The effective pixels are the same as DVAL. The variable value depends on the Tap number of Camera Link. When the effective pixels (image width) are 0 or larger than the horizontal pixels: Effective pixels (image width) = Horizontal pixels
C8H: HAWE[7..0] C9H: HAWE[15..8]	[Horizontal AOI Effective Pixel AOI_E] Initial data: HAWE[15..0] = 0、 Range: 0 to 4,096 This command sets the number of effective pixels (image width). The effective pixels are the same as DVAL. The variable value depends on the Tap number of Camera Link. When the effective pixels (image width) are 0 or larger than the horizontal pixels: Effective pixels (image width) = Horizontal pixels
CAH: HAWF[7..0] CBH: HAWF[15..8]	[Horizontal AOI Effective Pixel AOI_F] Initial data: HAWF[15..0] = 0、 Range: 0 to 4,096 This command sets the number of effective pixels (image width). The effective pixels are the same as DVAL. The variable value depends on the Tap number of Camera Link. When the effective pixels (image width) are 0 or larger than the horizontal pixels: Effective pixels (image width) = Horizontal pixels
CCH: HAWG[7..0] CDH: HAWG[15..8]	[Horizontal AOI Effective Pixel AOI_G] Initial data: HAWG[15..0] = 0、 Range: 0 to 4,096 This command sets the number of effective pixels (image width). The effective pixels are the same as DVAL. The variable value depends on the Tap number of Camera Link. When the effective pixels (image width) are 0 or larger than the horizontal pixels: Effective pixels (image width) = Horizontal pixels
CEH: HAWH[7..0] CFH: HAWH[15..8]	[Horizontal AOI Effective Pixel AOI_H] Initial data: HAWH[15..0] = 0、 Range: 0 to 4,096 This command sets the number of effective pixels (image width). The effective pixels are the same as DVAL. The variable value depends on the Tap number of Camera Link. When the effective pixels (image width) are 0 or larger than the horizontal pixels: Effective pixels (image width) = Horizontal pixels

Command No.	Command Descriptions								
DEH: DEF_M[7..0]	<p>[Pixel defect correction mode1] Initial data: DEF_M [7..0] = 1 This command sets the pixel defect correction. ※For further details on the x-y coordinates of the defect pixel, please refer to: Device Code:3AH</p> <p>D[7..0]</p> <table border="1"> <tr> <td>D7</td><td>D6</td><td>D5</td><td>D4</td><td>D3</td><td>D2</td><td>D1</td><td>D0</td> </tr> </table> <p>D7 to D4: 座標上位アドレス 0 to 3 D3 to D2: No Function Always set as "00" D1: Highlight the corrected pixel <u>0: Disable</u> 1: Enable D0: Pixel Defect Correction <u>0: Disable</u> <u>1: Enable</u></p> <p>When Highlight the corrected pixel is Enabled, the corrected pixel will be highlighted. ※D7 to D4 is Device Code : to set the X-Y coordinate of defect pixel with 3AH.</p>	D7	D6	D5	D4	D3	D2	D1	D0
D7	D6	D5	D4	D3	D2	D1	D0		
DFH: DEF_M2[7..0]	<p>[Pixel defect correction mode 2] Initial data : DEF_M2[7..0] = 70H This command sets the artificial effect with pixel defect correction.</p> <p>D[7..0]</p> <table border="1"> <tr> <td>D7</td><td>D6</td><td>D5</td><td>D4</td><td>D3</td><td>D2</td><td>D1</td><td>D0</td> </tr> </table> <p>D7: No Function Always set as "0" D6: AOI <u>0: Disable</u> 1: Enable D5: Vertical Flip <u>0: Disable</u> 1: Enable D4: Horizontal Flip <u>0: Disable</u> 1: Enable D3 to D0 No Function Always set as "0000"</p> <p>※For further details on the x-y coordinates of the defect pixel, please refer to: Device Code:3AH</p>	D7	D6	D5	D4	D3	D2	D1	D0
D7	D6	D5	D4	D3	D2	D1	D0		
E3H: FPN[7..0]	<p>[FPN Correction Mode] Initial data: FPN[7..0] = 17 This command sets the FPN Correction (※FPN : Fixed Pattern Noise).</p> <p>D[7..0]</p> <table border="1"> <tr> <td>D7</td><td>D6</td><td>D5</td><td>D4</td><td>D3</td><td>D2</td><td>D1</td><td>D0</td> </tr> </table> <p>D7 to D0: FPN Correction Mode 0: Disable <u>17: Enable</u></p>	D7	D6	D5	D4	D3	D2	D1	D0
D7	D6	D5	D4	D3	D2	D1	D0		
EEH: MOD6[7..0] EFH MOD6[15..8]	<p>[The camera function mode] Initial data: MOD6 [7..0] = 3 This command sets the camera TAP number for each setting.</p> <p>D15 to D0: TAP Number</p> <p><u>0: 2 TAP</u> 1: 4 TAP 2: 8 TAP 3: 10 TAP 4-15: No function 16: 3 TAP More than 17: No function</p>								

6.4.3 Camera Control Command List (Device Code:3AH)

The actual 256points of Pixel Blemish Correction (PB Correction) Values are stored on this address.

600points

The data size of each Command No. is 1 Byte (8bit)

"EEPROM" on the table shows the access on EEPROM

(○: can be saved on EEPROM, ×: cannot be saved on EEPROM)

When the cameras are initially shipped, defected pixels were corrected and the information stored into the EEPROM for each camera.

When the rest of the points still exist, FFFFh will be stored as the initial data on the X,Y Points. These parameters can be used.

When the camera is turned on, these values will be initialized as saved EEPROM data.

Device Code : 3AH (Device Code 00H DEh[7..4] = 0)

Command No.	R/W	EEPROM	Function	Initial Data	Data Range
00H	R/W	○	X1 point of PB Correction (16bit : D[7..0])	FFFFh (PB Correction OFF)	0 to 4095
01H	R/W	○	X1 point of PB Correction (16bit : D[15..8])		
02H	R/W	○	Y1 point of PB Correction (16bit : D[7..0])	FFFFh (PB Correction OFF)	0 to 3071
03H	R/W	○	Y1 point of PB Correction (16bit : D[15..8])		
to					
FCH	R/W	○	X64 point of PB Correction (16bit : D[7..0])	FFFFh (PB Correction OFF)	0 to 4095
FDH	R/W	○	X64 point of PB Correction (16bit : D[15..8])		
FEH	R/W	○	Y64 point of PB Correction (16bit : D[7..0])	FFFFh (PB Correction OFF)	0 to 3071
FFH	R/W	○	Y64 point of PB Correction (16bit : D[15..8])		

Device Code : 3AH (Device Code 00H DEh[7..4] = 1)

Command No.	R/W	EEPROM	Function	Initial Data	Data Range
00H	R/W	○	X65 point of PB Correction (16bit : D[7..0])	FFFFh (PB Correction OFF)	0 to 4095
01H	R/W	○	X65 point of PB Correction (16bit : D[15..8])		
02H	R/W	○	Y65 point of PB Correction (16bit : D[7..0])	FFFFh (PB Correction OFF)	0 to 30711
03H	R/W	○	Y65 point of PB Correction (16bit : D[15..8])		
to					
FCH	R/W	○	X128 point of PB Correction (16bit : D[7..0])	FFFFh (PB Correction OFF)	0 to 4095
FDH	R/W	○	X128 point of PB Correction (16bit : D[15..8])		
FEH	R/W	○	Y128 point of PB Correction (16bit : D[7..0])	FFFFh (PB Correction OFF)	0 to 30711
FFH	R/W	○	Y128 point of PB Correction (16bit : D[15..8])		

Device Code : 3AH (Device Code 00H DEh[7..4] = 2)

Command No.	R/W	EEPROM	Function	Initial Data	Data Range
00H	R/W	○	X129 point of PB Correction (16bit : D[7..0])	FFFFh	0 to 4095
01H	R/W	○	X129 point of PB Correction (16bit : D[15..8])	(PB Correction OFF)	
02H	R/W	○	Y129 point of PB Correction (16bit : D[7..0])	FFFFh	0 to 3071
03H	R/W	○	Y129 point of PB Correction (16bit : D[15..8])	(PB Correction OFF)	
to					
1CH	R/W	○	X192 point of PB Correction (16bit : D[7..0])	FFFFh	0 to 4095
1DH	R/W	○	X192 point of PB Correction (16bit : D[15..8])	(PB Correction OFF)	
1EH	R/W	○	Y192 point of PB Correction (16bit : D[7..0])	FFFFh	0 to 3071
1FH	R/W	○	Y192 point of PB Correction (16bit : D[15..8])	(PB Correction OFF)	

Device Code : 3AH (Device Code 00H DEh[7..4] = 3)

Command No.	R/W	EEPROM	Function	Initial Data	Data Range
00H	R/W	○	X193 point of PB Correction (16bit : D[7..0])	FFFFh	0 to 4095
01H	R/W	○	X193 point of PB Correction (16bit : D[15..8])	(PB Correction OFF)	
02H	R/W	○	Y193 point of PB Correction (16bit : D[7..0])	FFFFh	0 to 3071
03H	R/W	○	Y193 point of PB Correction (16bit : D[15..8])	(PB Correction OFF)	
to					
FCH	R/W	○	X256 point of PB Correction (16bit : D[7..0])	FFFFh	0 to 4095
FDH	R/W	○	X256 point of PB Correction (16bit : D[15..8])	(PB Correction OFF)	
FEH	R/W	○	Y256 point of PB Correction (16bit : D[7..0])	FFFFh	0 to 3071
FFH	R/W	○	Y256 point of PB Correction (16bit : D[15..8])	(PB Correction OFF)	

Device Code : 3AH (Device Code 00H DEh[7..4] = 4)

Command No.	R/W	EEPROM	Function	Initial Data	Data Range
00H	R/W	○	X193 point of PB Correction (16bit : D[7..0])	FFFFh	0 to 4095
01H	R/W	○	X193 point of PB Correction (16bit : D[15..8])	(PB Correction OFF)	
02H	R/W	○	Y193 point of PB Correction (16bit : D[7..0])	FFFFh	0 to 3071
03H	R/W	○	Y193 point of PB Correction (16bit : D[15..8])	(PB Correction OFF)	
to					
FCH	R/W	○	X256 point of PB Correction (16bit : D[7..0])	FFFFh	0 to 4095
FDH	R/W	○	X256 point of PB Correction (16bit : D[15..8])	(PB Correction OFF)	
FEH	R/W	○	Y256 point of PB Correction (16bit : D[7..0])	FFFFh	0 to 3071
FFH	R/W	○	Y256 point of PB Correction (16bit : D[15..8])	(PB Correction OFF)	

Device Code : 3AH (Code 00H DEh[7..4] = 5)

Command No.	R/W	EEPROM	Function	Initial Data	Data Range
00H	R/W	○	X321 point of PB Correction (16bit : D[7..0])	FFFFh	0 to 4095
01H	R/W	○	X321 point of PB Correction (16bit : D[15..8])	(PB Correction OFF)	
02H	R/W	○	X321 point of PB Correction (16bit : D[7..0])	FFFFh	0 to 3071
03H	R/W	○	X321 point of PB Correction (16bit : D[15..8])	(PB Correction OFF)	
~					
FCH	R/W	○	X384 point of PB Correction (16bit : D[7..0])	FFFFh	0 to 4095
FDH	R/W	○	X384 point of PB Correction (16bit : D[15..8])	(PB Correction OFF)	
FEH	R/W	○	X384 point of PB Correction (16bit : D[7..0])	FFFFh	0 to 3071
FFH	R/W	○	X384 point of PB Correction (16bit : D[15..8])	(PB Correction OFF)	

Device Code : 3AH (Device Code 00H DEh[7..4] = 6)

Command No.	R/W	EEPROM	Function	Initial Data	Data Range
00H	R/W	○	X389 point of PB Correction (16bit : D[7..0])	FFFFh	0 to 4095
01H	R/W	○	X389 point of PB Correction (16bit : D[15..8])	(PB Correction OFF)	
02H	R/W	○	X389 point of PB Correction (16bit : D[7..0])	FFFFh	0 to 3071
03H	R/W	○	X389 point of PB Correction (16bit : D[15..8])	(PB Correction OFF)	
~					
FCH	R/W	○	X448 point of PB Correction (16bit : D[7..0])	FFFFh	0 to 4095
FDH	R/W	○	X448 point of PB Correction (16bit : D[15..8])	(PB Correction OFF)	
FEH	R/W	○	X448 point of PB Correction (16bit : D[7..0])	FFFFh	0 to 3071
FFH	R/W	○	X448 point of PB Correction (16bit : D[15..8])	(PB Correction OFF)	

Device Code : 3AH (Device Code 00H DEh[7..4] = 7)

Command No.	R/W	EEPROM	Function	Initial Data	Data Range
00H	R/W	○	X449 point of PB Correction (16bit : D[7..0])	FFFFh	0 to 4095
01H	R/W	○	X449 point of PB Correction (16bit : D[15..8])	(PB Correction OFF)	
02H	R/W	○	X449 point of PB Correction (16bit : D[7..0])	FFFFh	0 to 3071
03H	R/W	○	X449 point of PB Correction (16bit : D[15..8])	(PB Correction OFF)	
~					
FCH	R/W	○	X512 point of PB Correction (16bit : D[7..0])	FFFFh	0 to 4095
FDH	R/W	○	X512 point of PB Correction (16bit : D[15..8])	(PB Correction OFF)	
FEH	R/W	○	X512 point of PB Correction (16bit : D[7..0])	FFFFh	0 to 3071
FFH	R/W	○	X512 point of PB Correction (16bit : D[15..8])	(PB Correction OFF)	

Device Code : 3AH (Device Code 00H DEh[7..4] = 8)

Command No.	R/W	EEPROM	Function	Initial Data	Data Range
00H	R/W	○	X513 point of PB Correction (16bit : D[7..0])	FFFFh (PB Correction OFF)	0 to 4095
01H	R/W	○	X513 point of PB Correction (16bit : D[15..8])		
02H	R/W	○	X513 point of PB Correction (16bit : D[7..0])	FFFFh (PB Correction OFF)	0 to 3071
03H	R/W	○	X513 point of PB Correction (16bit : D[15..8])		
~					
FCH	R/W	○	X576 point of PB Correction (16bit : D[7..0])	FFFFh (PB Correction OFF)	0 to 4095
FDH	R/W	○	X576 point of PB Correction (16bit : D[15..8])		
FEH	R/W	○	X576 point of PB Correction (16bit : D[7..0])	FFFFh (PB Correction OFF)	0 to 3071
FFH	R/W	○	X576 point of PB Correction		

Device Code : 3AH (Device Code 00H DEh[7..4] = 9)

Command No.	R/W	EEPROM	Function	Initial Data	Data Range
00H	R/W	○	X577 point of PB Correction (16bit : D[7..0])	FFFFh	0 to 4095
01H	R/W	○	X577 point of PB Correction (16bit : D[15..8])		
02H	R/W	○	X577 point of PB Correction (16bit : D[7..0])	FFFFh	0 to 3071
03H	R/W	○	X577 point of PB Correction (16bit : D[15..8])		
~					
5CH	R/W	○	X600 point of PB Correction (16bit : D[7..0])	FFFFh	0 to 4095
5DH	R/W	○	X600 point of PB Correction (16bit : D[15..8])		
5EH	R/W	○	X600 point of PB Correction (16bit : D[7..0])	FFFFh	0 to 3071
5FH	R/W	○	X600 point of PB Correction (16bit : D[15..8])		

A. Command sequence for saving to the EEPROM:

Please use the command sequence shown below in order to save to the EEPROM.

- 1) Set "1" to 80H.0 in order to activate "write control to the EEPROM".
- 2) Send the command and the save data with the EEPROM access command, which is set to "1" for the page selection.
- 3) The camera will send back one of the following receive codes after writing to the EEPROM:
01H: OK
10H: EEPROM write error
- 4) 80H.0 is changed to "0" automatically after write EEPROM.

Note.1) DO NOT save to the EEPROM when 80H.0 is set to "0".

Note.2) When saving multiple sequence commands to the EEPROM, all data should be saved to the EEPROM by one operation from 1) to 4).

Example of the multiple sequence commands: "10H, 11H, 12H and 13H" or "22H, 23H and 24H".

Note.3) When saving multiple command data, that are not sequenced commands, to the EEPROM, it is necessary to operate the number of times from 1) to 4).

Example of multiple commands: "10H, 13H, 19H and 1BH" or "20H, 23H and 25H".

8 Control Software

8.1 Summary

After installing the control software and launching “CLCtrl2.exe”, the main window will appear as shown below:

Menu
For further details, please refer to the following page.

Camera Setting Parameters
For further details, please refer to section: [SOFTWARE FUNCTION \(STANDARD\)](#).

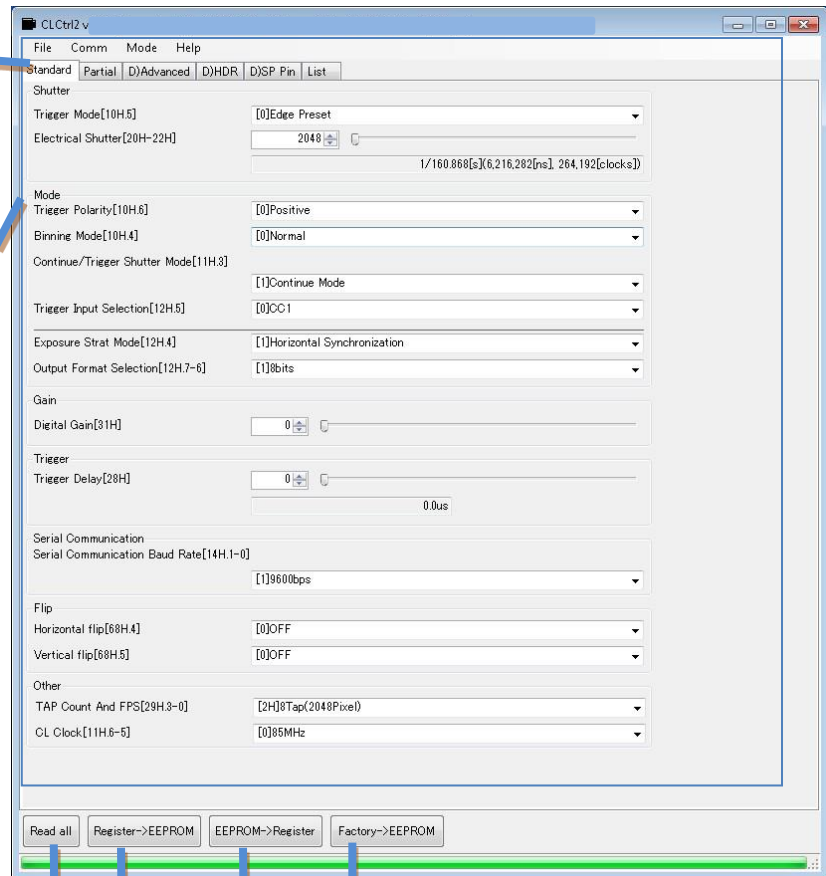

Load the factory saved settings data to EEPROM .
For further details, please refer to section: [COMM](#).

Load the previously saved settings data from EEPROM to Register.
For further details, please refer to section: [COMM](#).

Save the camera setting data on the register to EEPROM.
For further details, please refer to section: [COMM](#).

Read the camera setting data from the Register.
For further details, please refer to section: [COMM](#).

8.1.1 File

Open[From File to Register]

This function opens the camera setting file (.i2c).

Save as[From Register to File]

This function saves the current camera setting data on the register to the PC as i2c file.

Open[From File to EEPROM]

This function opens the camera setting file (.i2c) that is read at power on.

Save as[From EEPROM to File]

This function saves the camera setting data on EEPROM to the PC as i2c file.

Quit

This function exits the control software.

8.1.2 Comm

Port Setting

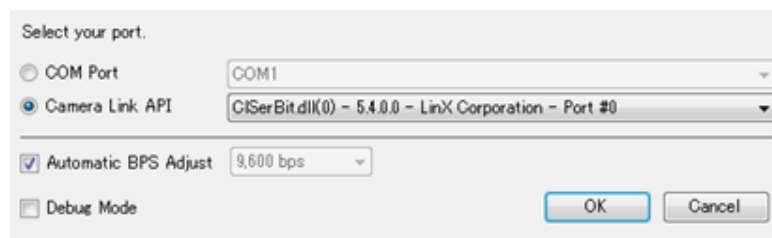

[Select your port]

COM port When the Grabber Board supports the COM port, please select this comand.

Camera Link API When the Grabber Board supports Camera Link API, please select this comand.

[Automatic BPS Adjust]

Select the serial communication speed automatically. When un-checked the box, communication speed can be selected.

[Debug Mode]

The box is un-checked as a default. When the box is checked, the transfer data can be monitored through 3rd party software.

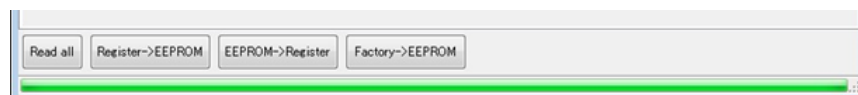

Read all

This function reads the settings of all the data from the camera register. This setting data on the register cannot be saved without saving the EEPROM (**Register -> EEPROM**).

Register -> EEPROM

This function saves the register data into the EEPROM on the camera. When the camera is turned off, the data remains on the EEPROM.

EEPROM -> Register

This function reads the EEPROM data into the register.

Factory -> EEPROM

This function restores the factory setting data from the EEPROM to the register.

8.1.3 Mode

Language

This function selects the language from English or Japanese.

8.1.4 Help

Advanced Operation

When password (sentechcamera) is input, additional functions appear for advanced users SP Pin tab can be used.

Version Information

This function can be used to make the software information window appear.

8.2 Software Function (Standard)

This tab has the basic camera functions. The number (i.e [10H.5]) next to the function is the register address. For further details, please refer to section: [6.COMMUNICATION PROTOCOL SPECIFICATIONS.](#)

8.2.1 Shutter

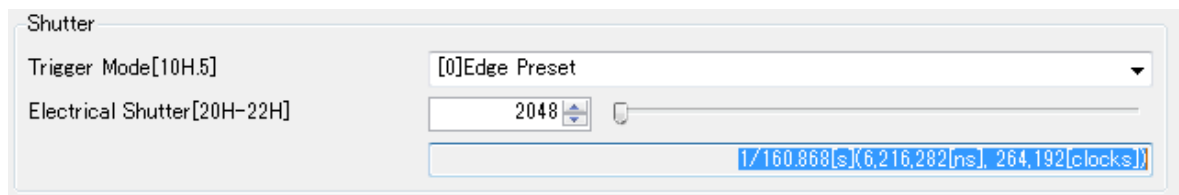

Trigger Mode

Edge Preset The camera exposure starts at the rising (or falling) edge of the trigger pulse. The exposure duration time is preset.

Pulse Width The camera exposure starts at the rising (or falling) edge of the trigger pulse and stops at the falling (or rising) edge of the trigger pulse.

For further details, please refer to section: [5.CAMERA FUNCTION MODES.](#)

Electrical Shutter

The electrical shutter setting can be set using the slide bar or through the actual register value. The actual exposure time appears on the bottom of the slide bar.

For further details, please refer to section: [6.COMMUNICATION PROTOCOL SPECIFICATIONS.](#)

8.2.2 Mode

Mode	
Trigger Polarity[10H.6]	[0]Positive
Binning Mode[10H.4]	[0]Normal
Continue/Trigger Shutter Mode[11H.3]	[1]Continue Mode
Trigger Input Selection[12H.5]	[0]CC1
Exposure Strat Mode[12H.4]	[1]Horizontal Synchronization
Output Format Selection[12H.7-6]	[1]8bits

Trigger Polarity

- Positive Positive signal is available as Trigger
- Negative Negative signal is available as Trigger

Binning Mode

- Normal Disable the binning
- Binning Enable the binning. For further details, please refer to: **Binning[2AH.5-4], Sub[2AH.1-0]**. The averaged pixel data will decrease the noise level. For further details, please refer to section: **8.2.6.OTHER.**

Continue/Trigger Shutter Mode

- Continue Mode This mode will obtain the image from the camera automatically. The trigger is generated inside of the camera continuously.
- Trigger Shutter Mode This mode will obtain the image from the external trigger timing. When this mode is selected the Edge Preset & Pulse Width on the [Trigger Mode] are available.

For further details, please refer to section: **5.CAMERA FUNCTION MODES.**

Trigger Input Selection

- CC1: Trigger signal input from the Camera Link connector on pin CC1.
- SP4: Trigger signal input from I/O port. For further details, please refer to section: **9.1.USING THE TRIGGER SIGNAL THROUGH 6PIN.**

Exposure Start Mode

- Normal: The exposure will start after the trigger input. The exposure can start during the video out from the camera with horizontal noise.
- Horizontal Synchronization: The exposure can start during the video out from the camera without horizontal noise. The maximum delay to start exposure from the trigger inputs in 1H.
- Output Format Selection: The video output bit can be selected from either 8/10/12 bit and is different depending on the mode. For further details, please refer to section: **4.2 VERTICAL TIMINGS.**

8.2.3 Gain

Gain

Digital Gain[31H]

Digital Gain

This function sets the value of digital gain. For further details, please refer to:[31H](#).

Trigger

Trigger

Trigger Delay[28H]

Trigger Delay

This function sets the delay time for the trigger. For further details, please refer to:[28H](#).

8.2.4 Serial Communication

Serial Communication

Serial Communication Baud Rate[14H.1-0]

Serial Communication Baud Rate

This function selects the baud rate.

8.2.5 Flip

Flip

Horizontal flip[68H.4]

Vertical flip[68H.5]

Horizontal flip

- OFF Normal image
- ON Horizontal Mirror image

Vertical flip

- OFF Normal image
- ON Vertical Mirror image

8.2.6 Other

Other

TAP Count And FPS[29H.3-0]

CL Clock[11H.6-5]

TAP Count And FPS

The TAP number can be selected by the frame rate, Camera Link Output Bit and Video mode. For further details, please refer to section: [4.2 VERTICAL TIMINGS](#).

8.3 Software Function (Partial)

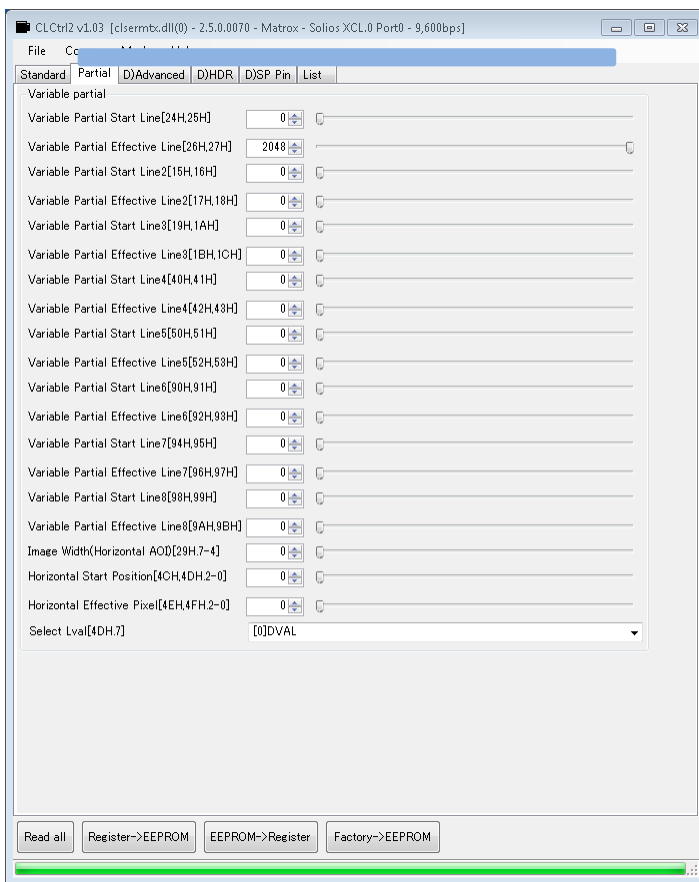

Variable partial

This function sets the partial scan. For further details, please refer to section: [6.COMMUNICATION PROTOCOL SPECIFICATIONS.](#)

8.4 Software Function (Advanced)

This tab is used for the factory default setting and should not be used.

8.5 Software Function (HDR)

This tab is used for an advanced user to control the Gamma. This cannot be used with the Color Model.

8.6 Software Function (SP Pin)

This function can be used to set the external trigger. For further details, please refer to section: [9.1. USING THE TRIGGER SIGNAL THROUGH 6PIN.](#)

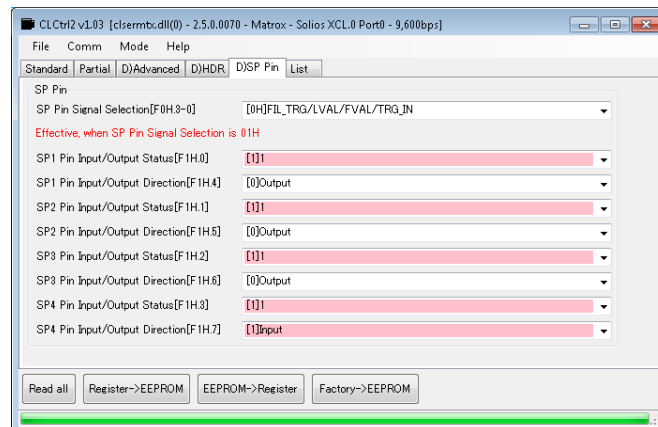

9 Actual Camera Setting & Technical Notes

9.1 Using the Trigger Signal through 6pin

1. Select "[0] Trigger Shutter Mode (Long Exposure)" on Continue/Trigger Shutter Mode Selection at Standard tab through the control software (CLCtrl2).
2. Select "[0H] FIL_TRG/LVAL/FVAL_TRG_IN" on SP Pin Signal Selection at SP_Pin tab.
3. Input the trigger signal through Pin2. For further details, please refer to section: [7](#).

CONTROL Software.

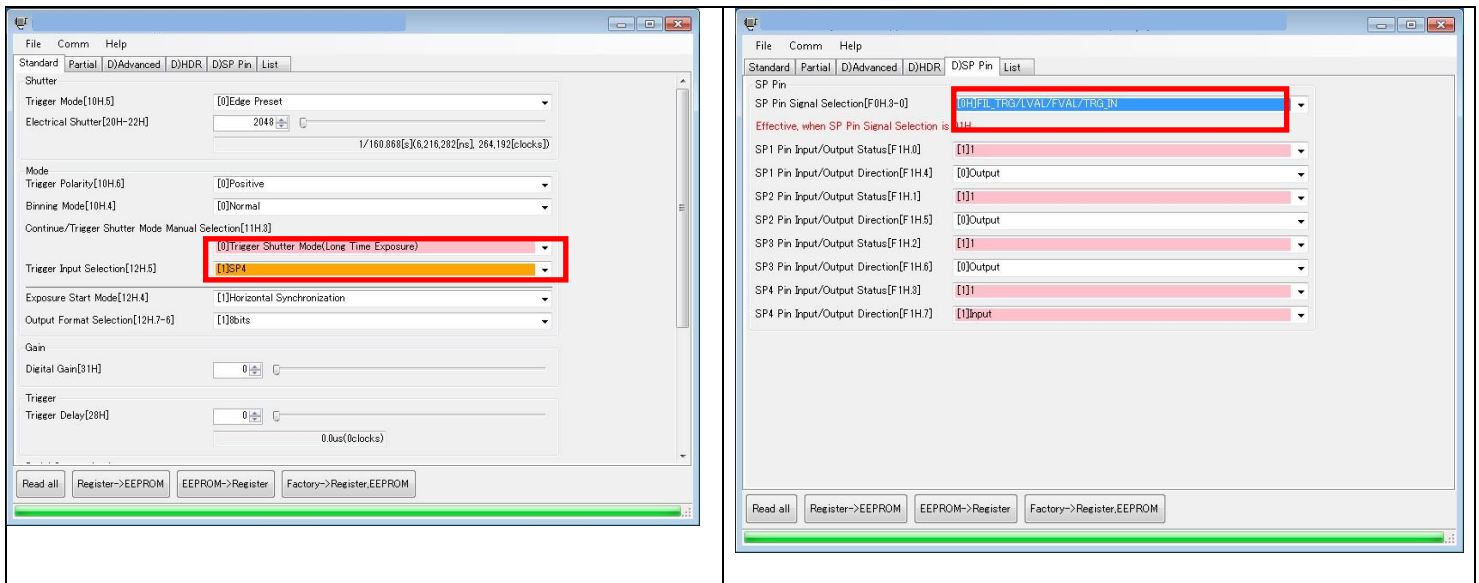

SP Pin Signal Selection Table

Pin No	5	4	3	2
Addr=F0	SP1	SP2	SP3	SP4
0	AfterTrigger FILTER	LVAL	FVAL	Trigger Input
1	F1h.0	F1h.1	F1h.2	F1h.3
7	LVAL	CC1	HIGH in Exposure	FVAL
Others	Reserved			

10 Revision History

Revisions

Rev	Date	Changes	Note
0.08	2013/07/31	New document	
0.09	2013/08/20	Revised Color Bayer pattern, Minimum exposure time	
0.10	2013/09/03	Revised Dimensions	
0.11	2013/10/10	Revised Camera name : STC-CMB120APCL,STC-CMC120APCL-YM Added: Pixel Blemishes correction register: DEH,DFH Device Code: 3AH Initial value of exposure time revised to micro second unit (10H[0] = 1) Signal Selection table of 6Pin assignment (F0H) was revised	
0.12	2013/10/21	Revised Added 42.5MHz on CameraLink Clock(11H[6:5]) Added Horizontal Sync Synchronization (12H[4]) Revised Initial data on 12H[7:0] = 0 x 50 Revised Clamp Level on 38H[7:0] range to 0 to 80 Added the explanation of AOIR_A on 90-91H. Added FPN(Fixed Pattern Noise) register on E3H	
0.13	2013/10/25	Revised Added Factory Default LoadRegister(81H[0]) Revised the information around Camera Control Command list(3AH)	
0.14	2013/01/20	Revised Revised 8TAP mode only	
0.15	2014/8/13	Updated to Full English Translation	RM

7F, Harada center building
9-17, Naka cho 4 chome
Atsugi-city, Kanagawa
243-0018 Japan

Sentech Co., Ltd

TEL +81-46-295-7061 FAX +81-46-295-7066
URL <http://www.sentech.co.jp/>