

SMS MEDIA CABINET INDOOR TOTEM



Protected messages in one or two directions.

This enclosure for indoor Digital Signage is as secure as it is attractive and allows you to meet visitors from two directions at the same time. The one or two LED backlit LCD displays are safely housed behind unbreakable Hammerglass (standard fitting). Other protection from external damage includes the drill-proof security locks and the robust black or white cover. A kick-rail and structured coating that ensure that any stains and marks are hardly visible are also standard equipment. Suitable for screens of size 55".

A comprehensive solution for commercial premises, public spaces and other locations in which the flow of visitors places high demands on the media equipment. Discreetly blends into different surroundings. Manufactured to order.

QUESTIONS AND ANSWERS

What is Digital Signage?

A solution that allows you to send targeted messages wherever you want.

What is the SMS Cabinet Indoor Totem?

A secure enclosure for indoor Digital Signage. The product stands on the floor and can be equipped with one or two displays placed back-to-back.

Can the glass in front of the screen be smashed?

No. The product is delivered with unbreakable Hammerglass.

What is Hammerglass?

Hammerglass is a polycarbonate sheet that cannot be scratched and that is 300 times stronger than glass. It is essentially unbreakable. A unique surface treatment of silicon oxide means that Hammerglass can resist most forms of chemical and acid attack. The surface treatment also gives 99.96% UV protection, which prevents the glass from clouding or fading.

Meet your target group at their level!

Exactly at eyelevel – but still giving a discrete impression.



The SMS Cabinet Indoor Totem is easy to position, and it is held securely in place (bolted to the floor). Hammerglass, safety locks, kick-rail and other features are all included as standard.

QUESTIONS AND ANSWERS

Is it possible to get into the cabinet by drilling the locks?

No. The SMS Media Cabinet Indoor Totem has two drill-proof high-security locks.

What do I need to consider when ordering?

Note that it is necessary to specify three article numbers for a complete product: Indoor cabinet – one or two cabinets, the totem support (single or double), and the VESA bars, one set for each display.

How is the product delivered?

The indoor cabinet is factory-assembled and is delivered in its own transport box. The totem support is delivered in a separate box. In addition, it is necessary to order the VESA bars, which are delivered in their own package.

How does being enclosed in a cabinet affect my display?

The SMS Media Cabinet Indoor is ventilated by natural ventilation. It is approximately 10 degrees warmer in the cabinet than the surroundings, when it is used with a LED-backlit LCD display of light intensity 500 cd/m² and a PC. A display with a higher power produces more heat. You must always check, therefore, the specified maximum operating temperature with the display supplier.

Can I mount the cabinet in a display window exposed to direct sunlight?

You can install it in direct sunlight only if the display supplier has certified the particular display model for such exposure.

What humidity does the product allow?

Always check the operating humidity with the supplier of your display.

Can I mount a high-brightness display in the cabinet?

High-brightness displays operate at a higher temperature. Consult the supplier of your display.

Technical specifications

INFO

- Finish: White or black.
- Cover: Robust coated metal of thickness 1.5-3 mm.
- Areas of application: Indoor installations where an attractive enclosure is required combined with protection against theft and vandalism.
- Display attachment: Select the VESA bars with their own article number, depending on the display that is to be used.
- Mounted in portrait mode.
- Glass: 8-10 mm unbreakable Hammerglass.
- Locks: The cabinet has two drill-proof locks (with keys).
- Kick-rail.
- Weight of totem: Single 55": 95 kg excluding the cabinet.
Double 55": 90 kg excluding the cabinet.
- Maximum display size: 55", 1270 x 760 x 50 mm.
- 1600 mm vertical distance from the floor to the centre of the display.
- Warranty: 5 years.

The product is manufactured to order.

Tailored solutions for colour and logo, for example, can be offered for series above a certain volume. Contact SMS or your distributor for more information.

| ART. NO. | DESCRIPTION |
|----------|-----------------------------|
| IN020015 | SMS Cabinet Indoor 55 White |
| IN020016 | SMS Cabinet Indoor 55 Black |

How to order:

- 1 Select one or two SMS Media Cabinet.
- 2 Select one or two sets of VESA bars based on the hole pattern of the display and setback-PC (where relevant).
- 3 Select the totem, either for a single display, Totem Single, or for mounting back-to-back, Totem Double.

VESA bars:

| | |
|----------|--|
| IN130001 | SMS Indoor VESA Bars 600x400 (these are not suitable for Samsung displays with a Setback-PC. We recommend in this case one of the article numbers below.) |
| IN130002 | SMS Indoor VESA Bars 400x400 |
| IN130003 | SMS Indoor VESA Bars 200x200 |

Totem:

| | |
|----------|---------------------------|
| IN041005 | SMS Totem Single 55 White |
| IN041006 | SMS Totem Single 55 Black |
| IN041105 | SMS Totem Double 55 White |
| IN041106 | SMS Totem Double 55 Black |

SMS Media Cabinet Totem Single 55

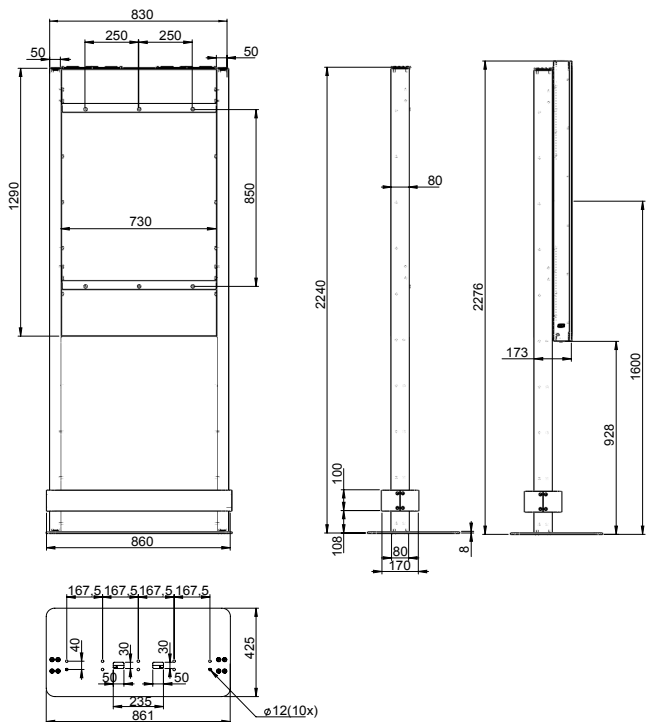

SMS Media Cabinet Totem Double 55

