



by Schneider Electric

DX4000 Series

Digital Video Recorders



Pelco Digital Video Recorders

Running a business of any size and keeping it profitable is no small task. While owners want to ensure safety and protect their investment, there often is not enough time in the day to manage daily security logistics. Pelco and the DX4000 series of digital video recorders can help. For the right features at the right price, look no further than Pelco DX4000 Digital Video Recorders.



Guarding Your Business. Protecting Your Bottom Line.



Ready-to-record right out of the box and exceptionally simple to operate, DX4000 Series digital video recorders come with a wireless remote control that greatly minimizes employee-training time. By using the remote client, users can keep watch over multiple locations at once.

DX4004, DX4500, and DX4600 DVRs utilize MPEG-4 compression technology for small files sizes and greater efficiencies when transmitting over today's broadband networks. With four-, eight-, and sixteen-channel models featuring impressive search capabilities, recording speeds

of up to 480 IPS, and internal storage capacity up to 3 TB, rest assured that the video you need is always at your fingertips. And with the ability to trigger recording and alarms on motion or external contacts, DX4000 DVRs deliver an automated monitoring system perfect for unattended applications.



It is easy to secure campuses and multi-building facilities with DX4000 systems. Take advantage of existing network infrastructure to transmit video to a remote client or web client for convenient viewing and management.

From basic stand alone to multi-location networked applications, the DX4000 Series provides the power and flexibility you need. These full-featured systems offer models supporting recording speeds of up to 480 IPS and up to 3 TB of internal storage. Combined with network capabilities the video you need is always at your fingertips with DX4000 DVRs.

Secure Video Backup

DX4000 Systems Backup Player is automatically downloaded with file exports and allows users to review video that has been backed up to the hard disk, a CD, DVR, or USB flash memory device. DX4000 Series DVRs also digitally watermark video as it is recorded. This digital watermark can be authenticated from the Backup Player.

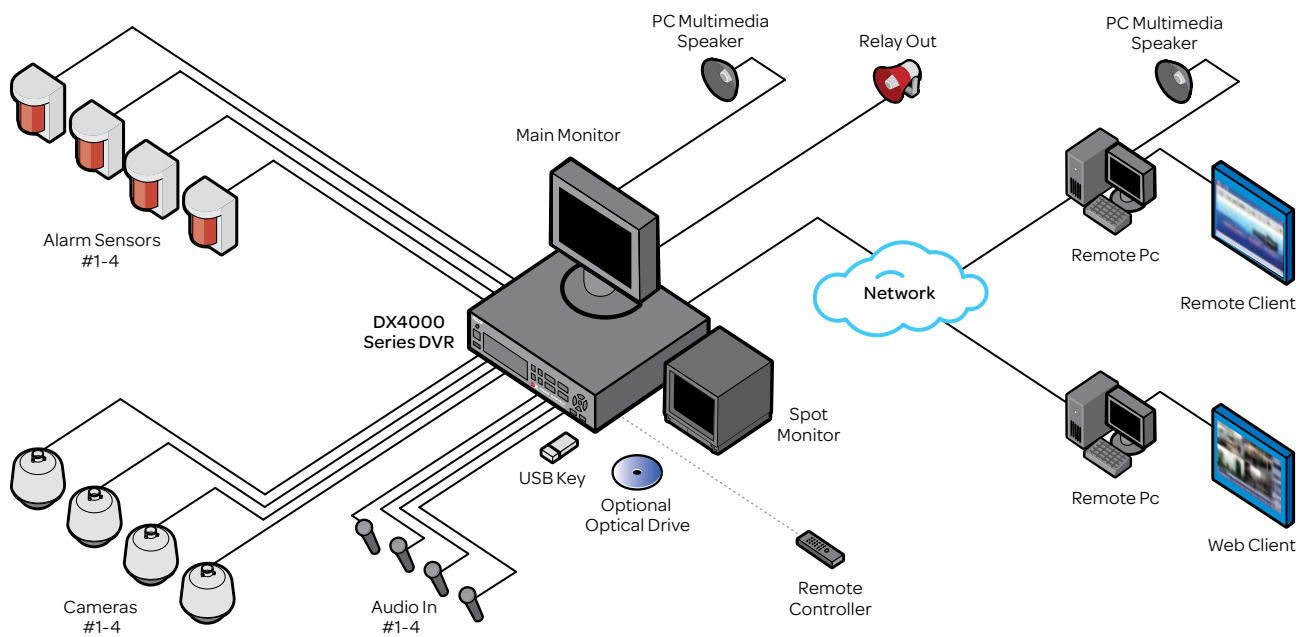

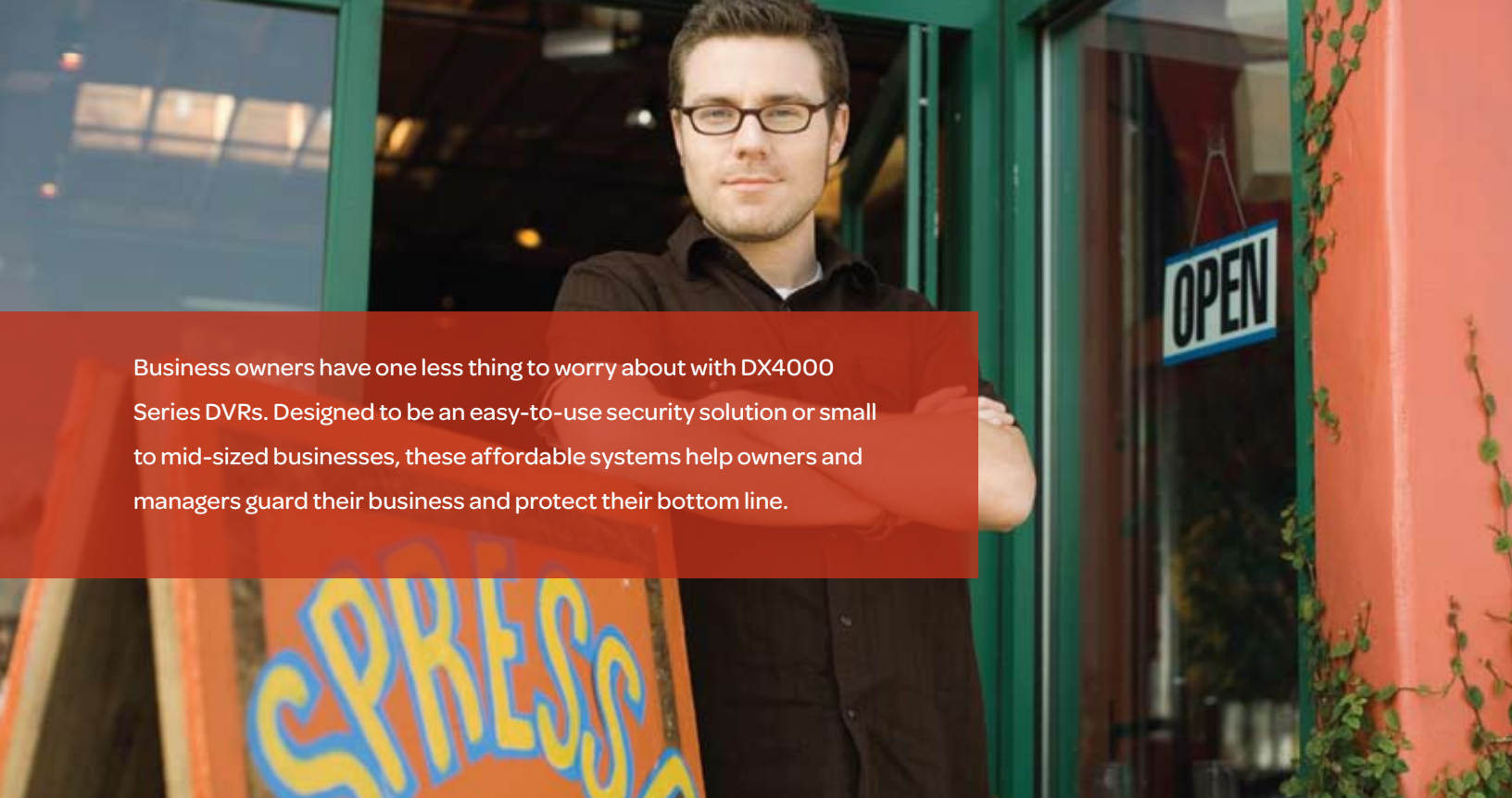

Business owners have one less thing to worry about with DX4000 Series DVRs. Designed to be an easy-to-use security solution for small to mid-sized businesses, these affordable systems help owners and managers guard their business and protect their bottom line.

Excellent Quality Images

With the ability to record at resolutions of up to 4 CIF, the DX4000 Series of DVRs capture crystal clear pictures and full-motion video, creating effective footage for later use and retrieval.

Flexible Recording Choices

Because recording resolutions, frame rates and image quality settings are adjustable on a camera-by-camera basis, DX4000 Series systems provide the flexibility needed to effectively utilize and manage HDD capacity. Additionally, DX4500 and DX4600 systems feature HDD Storage Manager, allowing users to specify how much space is allowed to alarm recording. The remaining storage is used for continuous recording.

Total Product Support

We will always do whatever it takes to make sure every customer is protected by Pelco's commitment to 100% Customer Satisfaction. With Off-the-Shelf Product Availability, Guaranteed Ship Dates, 24-Hour Service and Repair Guarantees, and Around-the-Clock Person-to-Person technical support, no one even comes close to matching the value of DX4000 Series Digital Video Recorders.



Unmatched Quality and Service

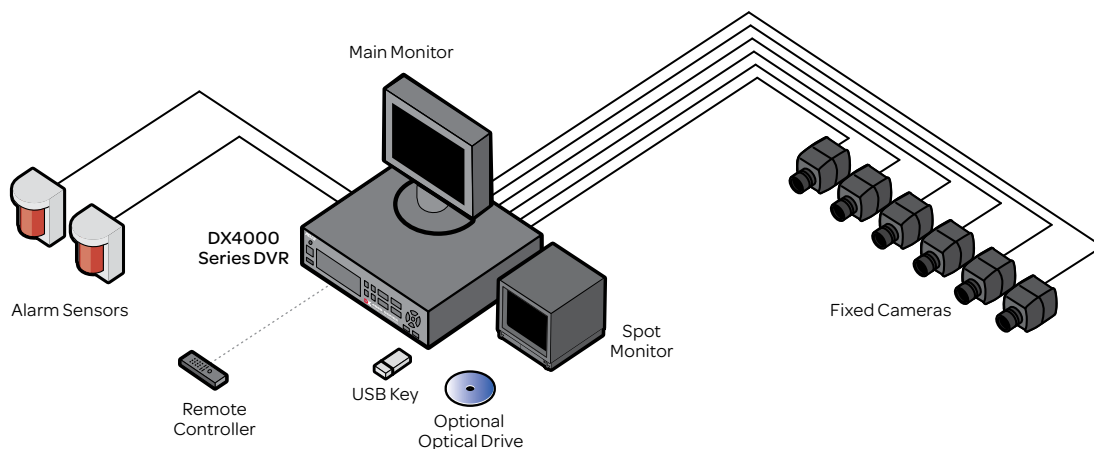

DX4000 Series DVR Models and Features



DX4000 Series systems deliver efficient hard drive storage of up to 3TB and optical disk drives make it easy to archive video critical for investigations. Packed with features, easy-to-use and affordably priced, these DVRs put the “easy” in your buying decision.

DX4004 Digital Video Recorder

- 4-Channel DVR
- Up to 120 Images Per Second (IPS) at CIF Resolution
- Up to 500 GB Maximum Internal Storage
- Independent Channel Resolution, Quality, and Frame Rate Settings
- Flexible Scheduling and Search Features
- Optional CD or DVD Optical Drives
- Internal PTZ Control, No Keyboard Needed
- Remote Client and Web Client



DX4004

DX4500 Digital Video Recorder

- 8- or 16-Channel DVR
- Up to 240 IPS at CIF Resolution
- Up to 1.5 TB Maximum Internal Storage
- Independent Channel Resolution, Quality, and Frame Rate Settings
- Flexible Scheduling and Search Features
- Optional CD or DVD Optical Drives
- Internal PTZ Control, No Keyboard Needed
- Remote Client
- Web Client
- Mail Notification and Emergency Agent



DX4500

DX4600 Digital Video Recorder

- 8- or 16-Channel DVR
- Up to 480 IPS at CIF Resolution
- Up to 3 TB Maximum Internal Storage
- Independent Channel Resolution, Quality, and Frame Rate Settings
- Flexible Scheduling and Search Features, including Pixel Search
- Optional DVD Optical Drive
- Internal PTZ Control, No Keyboard Needed
- Remote Client
- Web Client and Emergency Agent



DX4600

Model Selection Guide	DX4000	DX4500	DX4600
Series	DX40	DX45	DX46
Channels	04 = 4 Channels	08 = 8 Channels 16 = 16 Channels	08 = 8 Channels 16 = 16 Channels
Optical Drive	Blank = No Drive CD = CDRW DVD = DVDRW	Blank = No Drive CD = CDRW DVD = DVDRW	CD = CDRW DVD = DVDRW
Internal Storage	-160 = 160 GB -250 = 250 GB -500 = 500 GB	-250 = 250 GB -500 = 500 GB -750 = 750 GB -1000 = 1 TB -1500 = 1.5 TB	-250 = 250 GB -500 = 500 GB -750 = 750 GB -1000 = 1 TB -1500 = 1.5 TB -2000 = 2 TB -2250 = 2.25 TB -3000 = 3 TB

Feature	DX4004	DX4508	DX4516	DX4608	DX4616
Channels	4	8	16	8	16
IPS NTSC Recording	120	120	240	240	480
IPS PAL Recording	100	100	200	200	400
Pixel Search	No	No	No	Yes	Yes
Maximum Internal Storage (GB)	500	1500	1500	3000	3000
Audio Inputs	4	2	2	4	4
Alarms Inputs	4	8	8	16	16
Relay Outputs	1	2	2	4	4
Remote Client	Yes	Yes	Yes	Yes	Yes
Web Client	Yes	Yes	Yes	Yes	Yes
Mail Notification	No	Yes	Yes	Yes	Yes
Emergency Agent	No	Yes	Yes	Yes	Yes
Standard Optical Disk Drive	None	None	None	CD-RW	CD-RW
Optional Optical Disk Drive	CD-RW/ DVD ± RW	CD-RW/ DVD ± RW	CD-RW/ DVD ± RW	DVD ± RW	DVD ± RW



by **Schneider** Electric

The recognized worldwide leader in video and security systems, Pelco boasts the most comprehensive array of products, services and expertise available in today's marketplace. And now as a member of the Schneider Electric family, Pelco brings a network of assets backed by the strength of a Fortune 500 company to help you define and achieve your business objectives.

www.pelco.com

Pelco Inc. Worldwide Headquarters 3500 Pelco Way Clovis, California 93612 USA
(800) 289-9100 (800) 289-9150 Fax +1 (559) 292-1981 International +1 (559) 348-1120 International Fax

Worldwide Locations: Australia Canada China Finland France Germany Italy Macau The Netherlands
Russia Singapore South Africa Spain Sweden United Arab Emirates United Kingdom United States

Features and specifications subject to change without notice. ©Copyright 2008, Pelco. All rights reserved.

