



33.6W Power over Ethernet Adapter DC Input High Power Single Port Injector



Features

- Compliant with the IEEE802.3at Standard
- Diagnostic LEDs
- Non-Vented Case
- Classification per IEEE802.3at
- 1 Year Warranty
- UNH IOL Tested
- Full Protection OCP, OVP
- Gigabit Compatible
- DC Input Voltage 36-72VDC

Applications

- IP Telephones
- Wireless Network Access Points
- Blue Tooth Access Point
- Security Cameras with Pan/Tilt/Zoom
- IP Print Servers

Safety Approvals

- CE

Mechanical Characteristics

- Length: 140mm (5.51in)
- Width: 65mm (2.55in)
- Height: 36mm (1.42in)
- Weight: 0.2Kg (0.44lb.)

Output Specifications

Model	DC Output Voltage	Load		Regulation	
		Min.	Max.	Line	Load
POE36D-1AT	56V	0A	0.60A	54-57Vdc under all conditions	

Phihong is not responsible for any error, and reserves the right to make changes without notice. Please visit our website at www.phihong.com for the most up-to-date specifications and contact information.

INPUT:

DC Input Voltage Range
36 to 72VDC

DC Input Current
1.2A (DC) maximum for 36VDC

OUTPUT:
Total Output Power
33.6W at 56VDC

DC Offset
No data degradation with DC imbalance 18mA

Efficiency
80% (typical) at maximum load

Ripple and Regulation
100mV maximum

Transient O/P Voltage Protection
60V maximum at switch on and off

ENVIRONMENTAL:

Temperature
Operation -20 to +50°C
Non-operation -25 to +65°C

Humidity
Operation 5 to 90%

EMC
FCC Part 15 Class B
EN55022 Class B

Isolation Test

Primary to Secondary: 2121VDC for 1 minute
Primary to Field Ground: 2121VDC for 1 minute
Output to Field Ground: 2121VDC for 1 minute

Immunity

ESD: EN61000-4-2. Level 3
RS: EN61000-4-3. Level 2
EFT: EN61000-4-4. Level 2
Surge: EN61000-4-5. Level 3
CS: EN61000-4-6. Level 2
Voltage Dips EN61000-4-11
Harmonic: EN61000-3-2

Insulation Resistance

Primary to Secondary: >10M OHM 500VDC
Primary to Field Ground: >10M OHM 500VDC

FEATURE:

Over Voltage/Current, Short Circuit Protection

Outputs equipped with short circuit protection and overload protection as per 802.3at specification
The output can be shorted permanently without damage

Indicators

Green LED 1: Input power “ON”
Green LED 2: Valid IEEE8-2.3at load detected and connected “PoE PLUS”
Green LED 3: Valid IEEE802.3af load detected and connected

Input Connector

– Anytek OQ0355510000G
Mate – Anytek TJ0350520000G or TJ035152000G
Anytek is part of Giga-Way Technology Corp

Output Connection

+pins 3, 6
-pins 1, 2

Dimension Diagram Unit: mm (inch)

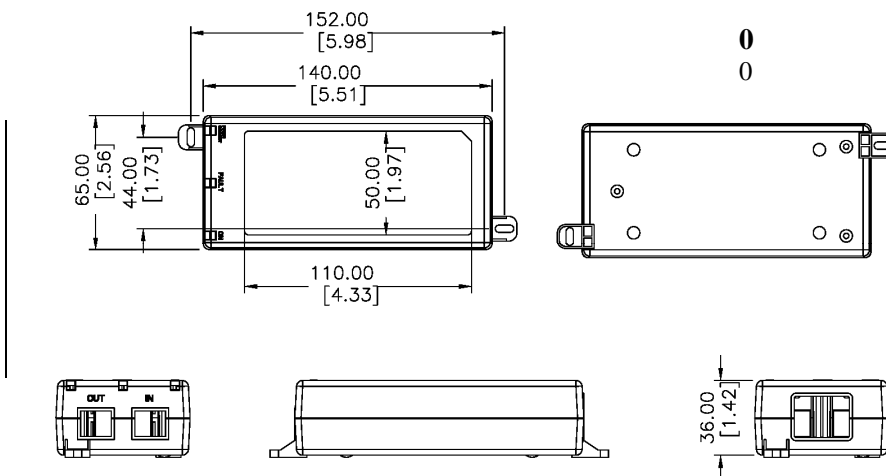



Gigabit Power Injector Block Diagram

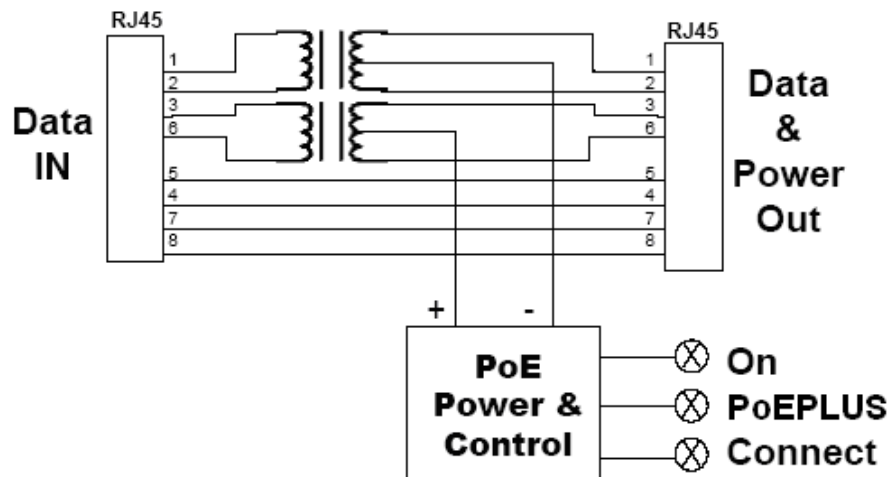

Description of LED Functions for Gigabit Power Injector

Power-up Sequence:

Upon power-up, all 3 LEDs will light for 2 seconds, as part of the self-test for the internal microprocessor software. After the end of the 2 seconds, the "ON" LED will illuminate green, signifying that the DC output voltage is available for powering a compliant load (to the 802.3at PoE standards).

Detection Sequence:

Once a compliant load is attached to the output RJ45 connector, the green "CONNECT" LED will illuminate. Should the load be classified as Class 4 PD, the green "PoEPLUS" LED will illuminate. Otherwise, "PoEPLUS" LED will stay off.

Should the load be non-compliant then the LEDs will blink a code signifying the cause for non-detection.

Detection Failure Codes:

1. Incorrect resistive signature – The green "CONNECT" and green "PoEPLUS" LEDs will blink 3 times.
2. Incorrect capacitive signature – The green "ON" LED will blink 3 times.
3. Incorrect Voffset – The green "CONNECT" and green "ON" LEDs will blink 3 times.
4. Unstable current measurement – The green "CONNECT" LED will blink 3 times
5. Low voltage sensed during detection (overload) – The green "PoE PLUS" LED will blink 3 times

After the LEDs blink 3 times the PSE will continue to try to detect a valid load. Therefore, until the correct load is applied, the LEDs will continue to blink. If there is an open circuit connected to the output RJ45 then the LEDs will not blink but the PSE will continue to try to detect a valid load.

Fault Sequence:

Should there be a fault such as an overload or short circuit then all the three LEDs will blink 5 times in 2 seconds, and then go off as the power supply tries to re-detect a valid load. If there is a problem in detecting, the LED will indicate what is wrong with the load as per the codes in the section above.