

MCR205-1T/1S

Fast Ethernet to SFP Managed Media Converter



OVERVIEW

The IFS Fast Ethernet to SFP Managed Media Converter is designed for the most demanding IP network applications offering the flexibility of SFP technology and remote network management for optimizing network performance.

SFP Technology

The IFS MCR205-1T/1S converts 10/100Mbps (TX) Ethernet on copper to 100Mbps (FX) fiber via Small Form-factor Pluggable (SFP) technology. This media converter can be custom configured to your exact system design specifications by utilizing a variety of IFS SFP Mini-GBIC modules. IFS SFP Mini-GBIC modules are available in a variety of versions from multi-mode or single mode fiber, 1 or 2 fibers and wide-temperature versions.

Enhanced Remote Management Features

For efficient management, the IFS Fast Ethernet to SFP Managed Media converter supports Simple Network Management Protocol (SNMP) and can be remotely managed via any standards-based management software.

Management functions include IP address configuration, DHCP Client function, port configuration, converter configuration, 802.1Q VLAN tagging, Q-in-Q VLAN, Ingress/Egress bandwidth control, QoS and Layer protocol filter, and broadcast storm control, to enhance bandwidth utilization.

In addition, the TS-1000/802.3ah OAM (operations, administration, and maintenance) protocol is supported which allows management and monitoring of a remote device via the MCR205-1T/1S media converter.

Unified Enclosure Design

The MCR205-1T/1S is designed with a unified enclosure that can be used in a standalone installation or can easily be inserted into the IFS MCR-R15 media converter rack. The IFS Media Converter Rack can provide DC power for up to 15 MCR Series Media Converters.

STANDARD FEATURES

Ethernet

- 10/100 Base-TX
- Complies with IEEE 802.3, IEEE 802.3u
- Auto-negotiation and MDI/MDI-X
- 10/100Base-TX: 2-pair Cat. 3/4/5 UTP cable, up to 100 meters

SFP (Mini-GBIC) Port

- IEEE 802.3u 100Base-FX standard
- 1 SFP slot provides custom configuration
- Optical fiber and distance varies by SFP (ordered separately)

Installation & Diagnostics

- Compact size, Plug-n-Play installation
- Unified design for stand-alone or rack-mount installation (MCR-R15 chassis)
- LED indicators for easy local network diagnostics
- Firmware upgradable via remote web interface
- Reset button to reset to factory default

Warranty

- 3-year warranty

Built-in Remote Network Management

- Layer 2 management
- Store-and-forward mechanism
- Built-in IP-based Web interface for remote management
- Manual IP address setting / DHCP client for IP address assignment
- Speed duplex mode configuration / flow control setting / bandwidth control on TP and SFP fiber interface
- SNMP v1 / v2c monitor / private Enterprise MIB
- Event trap and SNMP trap support
- Supports port status / Ethernet statistics on both TP and SFP fiber interface
- Supports maximum frame size to 16K bytes
- Loop detection / broadcast / multicast / unicast storm control
- Management VLAN / 16 IEEE 802.1Q VLAN groups / Q-in-Q VLAN
- 802.1p Tag Priority / IP address priority / IP DSCP option in Quality of Service Mode and Strict Priority / Weighted Round Robin (WRR) QoS policies
- TS-1000 OAM / IEEE 802.3ah OAM / Loop Back Test
- 16 TCP / UDP Filter groups

Specifications

Ethernet	Description
Data Rate	10/100 Base-TX port
Throughput (packet per second)	148810pps @ 64Bytes
Switch Architecture	Store-and-forward
Flow Control	Half/Full-duplex
Connector	RJ-45 (Auto-MDI/MDI-X)
Cable Type and Distance	10Base-T: 2-pair UTP Cat. 3,4,5, up to 100 m 100Base-TX: 2-pair UTP Cat. 5, up to 100 m

Fiber	Description
Data Rate	100Base-FX
Connector	SFP (Mini-GBIC) port
Fiber Type and Distance	Varies by SFP module

LED Indicators & Controls	Description
Power/Status	Green/On – power detected (+5VDC)
10/100Base-TX port link/activity	Green/On – link established Green/blinking – active port (TX/RX)
10/100Base-TX port speed	Green/On – 100Mbps half/full duplex mode operation Green/Off – 10Mbps half/full duplex mode operation
SFP (Mini-GBIC) port link	Green/On – link established Green/blinking – active port (TX/RX)
Reset button	Reset to factory default settings

Electrical & Mechanical	Description
Power	5VDC, 2A (3.3 watts)
Enclosure	Metal
Dimensions (W x D x H)	3.82 x 2.76 x 1.02 in. (97 x 70 x 26mm)
Weight	0.41 lbs. / 190 grams

Environmental	Description
Operating Temperature	0°C ~ 50°C
Storage Temperature	-10°C ~ 70°C
Relative Humidity	5% ~ 90% (non-condensing)
MTBF	> 50,000 hrs @ 25°C

Standards Compliance	Description
IEEE	IEEE 802.3, 10Base-T IEEE 802.3u, 100Base-TX IEEE 802.3u, 100Base-FX
EMI	EN 55022 CLASS A EN61000-3-2:2006 EN61000-3-3: 1995+1A:2001+A2:2005
EMS	EN 55024:1998+A1:2001+A2:2003 IEC 61000-4-2:2001 IEC 61000-4-3:2008 IEC 61000-4-4:2004 IEC 61000-4-5:2005 IEC 61000-4-6:2008 IEC 61000-4-8:2001

Dimensional Diagrams

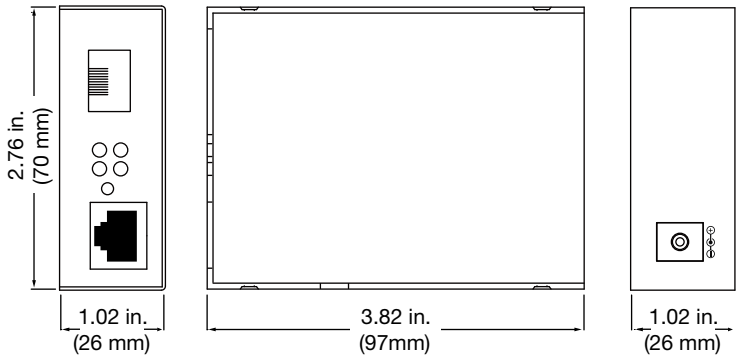

Typical Application

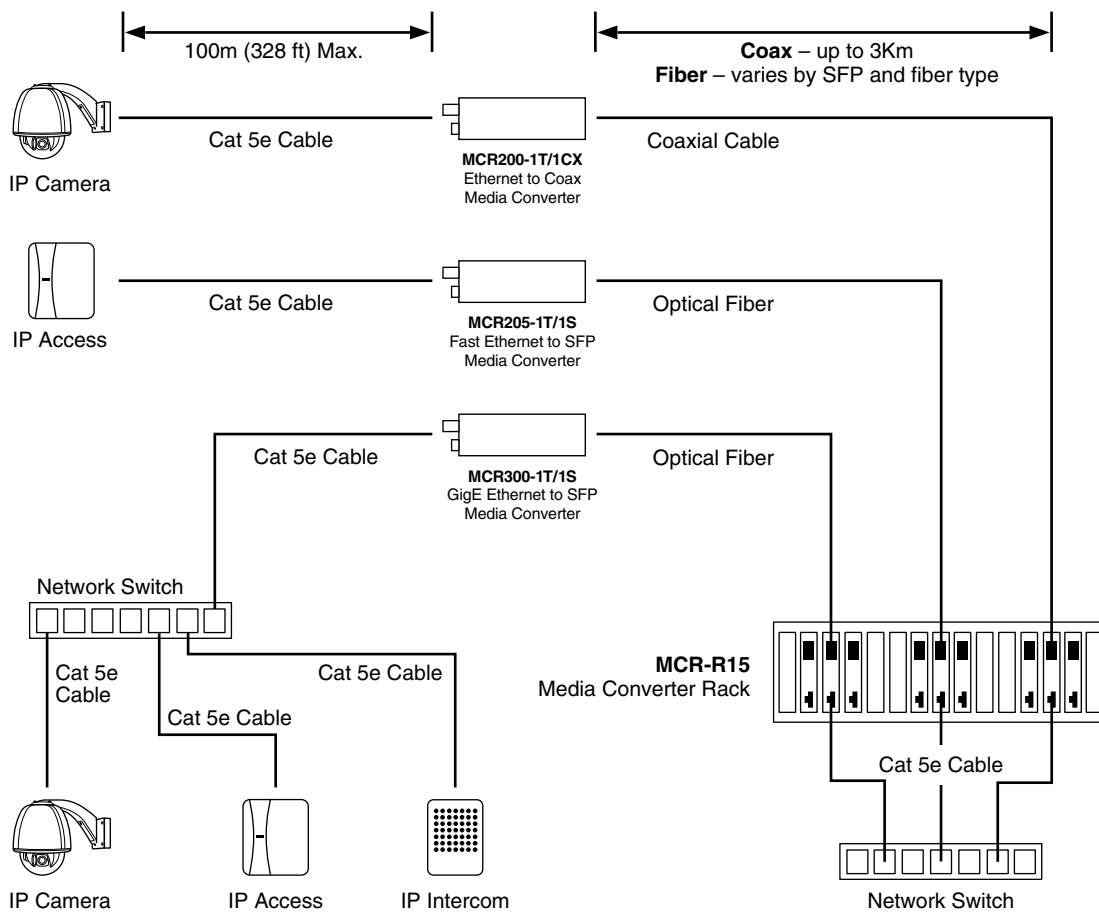

MCR205-1T/1S

North America
T 855-286-8889

Asia
T 852-2907-8108

Australia
T 61-3-9239-1200

Europe
T 32-2-725-11-20

Latin America
T 561-998-6114

Fast Ethernet to SFP
Managed Media Converter

Ordering Information

MCR205-1T/1S	Fast Ethernet to SFP Managed Media Converter
--------------	----------------------------------------------

Note: This unit requires a Small Form-factor Pluggable (SFP) for operation. IFS SFPs are available for multi-mode, single mode, 1 or 2 fibers for various transmission distances over optical fiber. Please refer to the IFS SFP data sheet to select the appropriate SFP for your particular application needs. This unit uses Fast Ethernet SFPs only.

Power Supply must be ordered separately.

Accessories

PS5VDC2A-US	5VDC@2A Wall-mount Power Supply
MCR-R15	MCR Series Media Converter Chassis

Specifications subject to change without notice.

© 2012 Interlogix, A UTC Fire & Security Company
All rights reserved.

2012/01 (68666H)



interlogix.com
utcfireandsecurity.com