

NVD100-XXR3

3 Independent Optical Channels 8-bit Digital Video Receiver



Features

Video

- ▶ NTSC or PAL video standards supported
- ▶ Non-compressed 8-bit digitally encoded video
- ▶ 3 independent channel receiver in one module
- ▶ No video degradation over the maximum operating distance

Optical

- ▶ Three independent fiber inputs
- ▶ High performance laser-based optics
- ▶ Multimode or Singlemode
- ▶ Internal SFP optical module
- ▶ ST or FC connectors available

Robust Design

- ▶ Plug-and-Play design, no in-field adjustments required.
- ▶ 2-in-1 modular design for standalone or rack-mount installation
- ▶ Hot-swappable design
- ▶ Wide operating temperature range of -40°C to +75°C
- ▶ Designed for use in harsh environments

Local and Remote Diagnostics

- ▶ Service-friendly LED status indicators on both front and rear of the module
- ▶ Remote health and status monitoring via Intelligent Rack System Diagnostics and Monitoring (SDM) Module

Warranty

- ▶ Comprehensive Lifetime Warranty

Description

The NeTrans' 8-Bit Digital Video transmission series' NVD100-XXR3 3-channel video fiber receivers feature high-performance laser-based optics for the clearest, most reliable data transmission over one fiber for both single and multi-mode with no video degradation over the entire operating distance (up to 20km). Supporting 3 independent channels of 8-bit PCM digital video, this plug-and-play product provides instant product compatibility for most major security manufacturers' equipment and reliability in harsh environments, a perfect compliment to any commercial, government or intelligent transportation application. The product features a universal design offering two great features: a variety of optical and connector options for field-configure-readiness; and a modular construction equipped for both rack-mount and stand-alone applications. The NeTrans Intelligent Rack design offers remote network diagnostics to maintain and manage system health and hot-swappability. These units are compatible with the NVD100Micro and NVD100 transmitters.

Typical Application

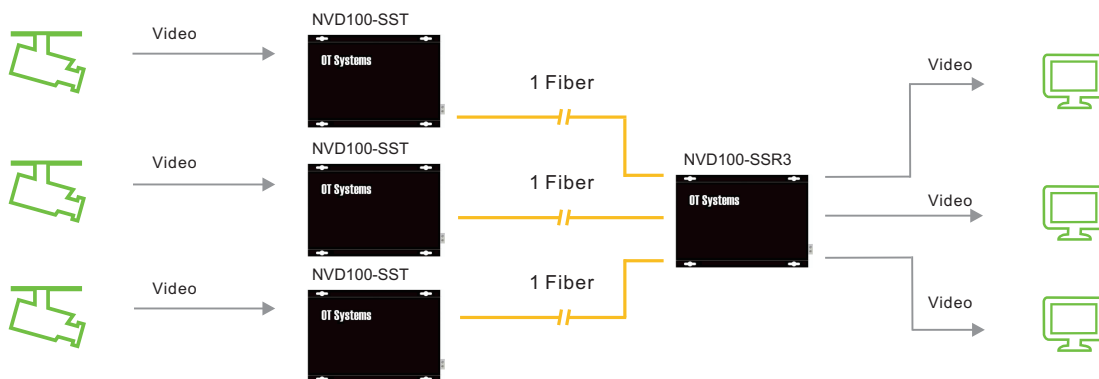

Video Transmission

Specifications

Video

Number of Channels	3 (from independent Transmitters)
Format	NTSC/PAL
Input/Output	1 Volt pk-pk (75 ohms)
Bandwidth	6MHz
Differential Gain	<2%
Differential Phase	<1 Degree Typical
SNR-CCIR weighted	>53dB

LED

Video Signal Indication (Presence/Absence)	Green/Red LED lit
Power	Green / On

Connectors

Video Output	BNC
Optical Input / Output	ST (standard), FC (optional)
Power (Standalone)	2-pin screw terminal
Power (Rack-Mount)	10-pin smart bus connector

Electrical and Mechanical

Power	SA: 12VDC @500mA
Dimensions(WxHxD)	158.4 x 25.4 x 231.8mm(Max)
Shipping Weight	0.8kg

Environmental

Operating Temp	-40 °C to +75 °C
Storage Temp	-40 °C to +85 °C
Relative Humidity	0 to 95% non-condensing
MTBF	> 100,000 hours

Ordering Information

Fiber Type	Part Number	Description	Wavelengths	Optical Power Budget	Max. Distance (Km)	No. of slots
Multi-mode (62.5/125µm)	NVD100-SMR3	3 Independent Optical Channels 8-Bit Digital Video Receiver	1310nm	12dB	4	1
Single-mode (9/125µm)	NVD100-SSR3	3 Independent Optical Channels 8-Bit Digital Video Receiver	1310nm	18dB	20	1

Options	<ul style="list-style-type: none"> ST type connector is standard. For FC type, specify "F" in the suffix. E.g. FMT. Please feel free to consult factory if longer transmission distance is required.
Power Adaptor	<ul style="list-style-type: none"> Power adaptor (GS40A12) is to be purchased separately. Please refer to accessories section for the details.
Rack Mount Chassis	<ul style="list-style-type: none"> Intelligent Rack Mount Chassis (NR-C14) is to be purchased separately. Please refer to accessories section for the details.

- Notes:
- Transmission distance will suffer if additional losses are introduced by the optical connectors, fusions, splices and the fibers within the network.
 - Operating distance of multimode is limited by the characteristics of the fiber bandwidth.
 - Power adaptor is manufactured by third party and is supplied with fitted screw - terminal output cables.
 - Please feel free to consult factory for any special requirement and customization.



OT Systems Ltd., June 2012

Due to continuous improvement, all product specifications are subject to change without further notice.