

SENTECH

USB 2.0 Slim Series Specification



Features

- USB 2.0 Interface
- Board or Cased Versions
- VGA - 1.3MP Resolutions
- 60 - 22 FPS

Caution for PCs with Intel Core i3, i5 or i7

- If the USB camera is used with a PC that has the Intel Core I series (i3, i5 and i7) chipset, the following problems may occur:

- An image cannot be obtained with the USB camera
- Frequent frame drop

This issue may occur with other USB camera manufacturers as well.

- Cause of the issue:

The image data cannot transfer to the PC because the Intel Core i3, i5 or i7 CPU frequently switches to the power save mode while the image is transferring.

- Solutions for the issue:

1. Disable the power save mode by changing the BIOS settings.

Users will be responsible for any changes made to the BIOS setting.

The power consumption and the heat of the PC will increase whenever the power save mode is disabled. Please understand and accept this before disabling the power save mode.

2. Disable the power save mode with the Sentech PC power management software (StPowerCtrl)

The power save mode can be disabled with the Sentech PC power management software “StPowerCtrl”.

A. Install “StCamSWare(v1.10)” or later revision.

B. Launch “StPowerCtrl” from Windows start => Sentech => StCamSWare.

C. Disable the two check boxes.

Before:

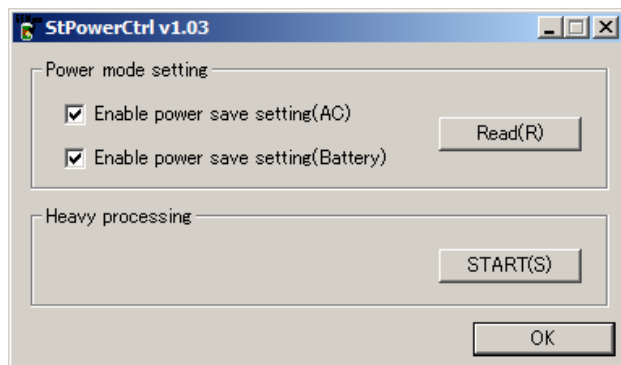

After:

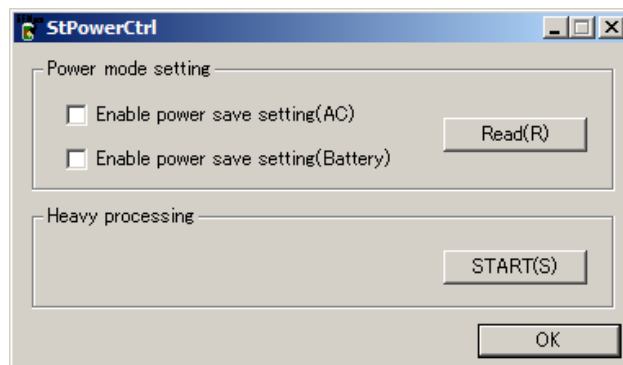

The power consumption and heat of the PC will increase when the power save mode is disabled. Please understand and accept this before disabling the power save mode.

3. Change the camera clock from “Normal” to “1/2” or “1/4”. (This will reduce the frame rate)

Contents

1	Overview	4
1.1	Features	4
1.2	Specification of Naming.....	4
1.3	Support Application.....	5
1.4	Power Supply	5
1.5	Pixel Blemish Static Collection and Saving Camera Settings.....	5
2	Specifications	6
2.1	STC-SC33USB / STC-SB33USB	6
2.1.1	Electronic Specifications.....	6
2.1.2	Mechanical Specifications	7
2.1.3	Environmental Specifications	7
2.1.4	Spectral Sensitivity Characteristics	8
2.2	STC-SC83USB / STC-SB83USB	9
2.2.1	Electronic Specifications.....	9
2.2.2	Mechanical Specifications	10
2.2.3	Environmental Specifications	10
2.2.4	Spectral Sensitivity Characteristics	11
2.3	STC-SC133USB / STC-SB133USB.....	12
2.3.1	Electronic Specifications.....	12
2.3.2	Mechanical Specifications	13
2.3.3	Environmental Specifications	13
2.3.4	Spectral Sensitivity Characteristics	14
3	Interface Connector Specifications (Board Type)	15
4	Input / Output signals specifications	16
4.1	Input signals specifications.....	16
4.1.1	Function for the input signals.....	16
4.1.2	Characteristics of the input signals.....	16
4.1.3	Input signal circuit (Including reset signal)	17
4.1.4	Reset signal	17
4.2	Output signals specifications	18
4.2.1	Function for the output signals	18
4.2.2	Characteristics of the output signals	18
4.2.3	Output signal circuit	19
5	Dimensions	20
5.1	STC-SCxxxUSB-BxCS (Color, Board Type, CS-Mount, USB Angle/Straight)	20
5.2	STC-SBxxxUSB-BLCS (Monochrome, Board Type, CS-Mount, USB Angle/Straight*)	21
5.3	STC-SCxxxUSB-BL / STC-SBxxxUSB-BL (Color / Monochrome, Board Type, No-Mount, USB Angle/Straight*) ..	21
5.4	STC-SCxxxUSB-BLL (Color, Board Type, Fixed Focus, USB Angle/Straight*)	22
5.5	STC-SBxxxUSB-BLL (Monochrome, Board Type, Fixed Focus, USB Angle/Straight*)	22
5.6	STC-SCxxxUSB-AL / STC-SBxxxUSB-AL (Color/Monochrome, Cased Type, CS-Mount*)	23
6	Revisions	24

1 Overview

This document describes the specification of the following cameras.

STC-SC33USB / SB33USB	(VGA)
STC-SC83USB / SB83USB	(XGA)
STC-SC133USB / SB133USB	(1.3M)

1.1 Features

- Small Size
- New camera reset function
- Up to 64 pixel blemish static collection
- 8,10,12bit output(10,12bit work only on Trigger or 1/2 clock free run mode)

1.2 Specification of Naming

STC-SxxxxUSB-xxx

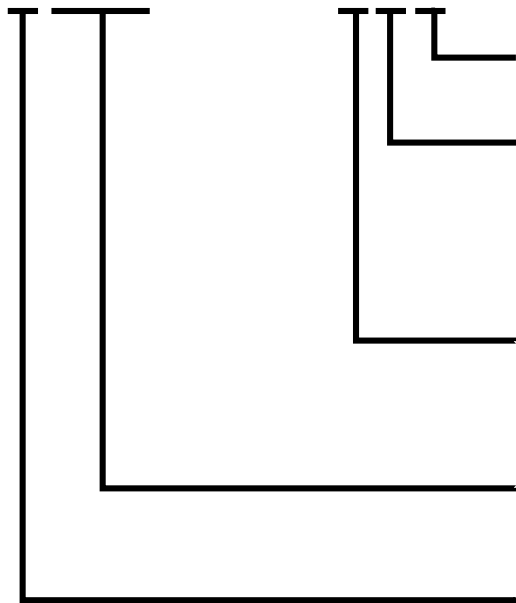

L: Micro Lens Mount
CS: CS Mount
None: Base Mount

L: USB "Right" angle connector
S: USB "Straight" angle connector only on Board Type
Both models have a Right angle IO connector

A: Case Type
B: Board Type

Resolution
33: VGA
83: XGA
133:1.3M

C: Color
B: Monochrome

1.3 Support Application

These models work with Sentech's viewing software (StCamSWare), SDK (TriggerSDK, StandardSDK) and sample codes. Some of the functions are not the same as other models (STC-TC/TB**USB-B series · STC-MC/MB**USB series). When the using this camera, please pay attention to the difference.

e.g.

- LED does not work on the sample code (StTrgDisplayVC2005.exe).
- Only two IO work on these models, even though Sentech's viewing software (StCamSWare) shows four IO.
- Product ID can be found through StCam_GetProductNam on SDK. However it can also be obtained through StCam_GetProductNam.

1.4 Power Supply

Sentech recommends using the USB port power cable when running the camera at 90fps in partial (or binning) mode.

USB port power cable

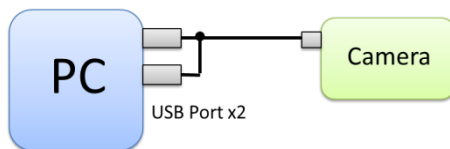

1.5 Pixel Blemish Static Collection and Saving Camera Settings

These cameras feature Pixel Blemish Static Collection and Camera Saving settings. The user can recover the factory default setting, as well as save the camera settings directly to a PC.

2 Specifications

2.1 STC-SC33USB / STC-SB33USB

2.1.1 Electronic Specifications

Product		STC-SC33USB	STC-SB33USB
Image Sensor		1/3" interline VGA color progressive CCD: ICX424AQ(Sony)	1/3" interline VGA B/W progressive CCD: ICX424AL(Sony)
Total picture elements		692(H) x 504(V)	
Effective picture elements		659(H) x 494(V)	
Chip size		5.79(H) x 4.89(V) mm	
Cell size		7.40(H) x 7.40(V) μm	
Scanning system		Progressive	
Resolution		640(H) x 480(V) (Full scanning) 640(H) x 224(V) (1/2 partial scanning) 640(H) x 80(V) (1/4 partial scanning)	
Scanning Methods		Full scanning, 1/1 partial scanning, 1/2 partial scanning, 1/4 partial scanning, Variable partial scanning	Full scanning, 1/1 partial scanning, 1/2 partial scanning, 1/4 partial scanning, Variable partial scanning, Binning scanning, Binning 1/1 partial scanning, Binning 1/2 partial scanning, Binning 1/4 partial scanning, Binning variable partial scanning
Max. Frame Rate	Full scanning	59.94 fps (Normal) / <u>29.97 fps (1/2clock)</u> / 14.98 fps (1/4clock) / 89.91 fps (3/2clock) *1	
	1/2 partial scanning	120.11 fps (Normal) / 60.05 fps (1/2clock) / 30.02 fps (1/4clock) / 180.165 fps (3/2clock)	
	1/4 partial scanning	240.22 fps (Normal) / 120.11 fps (1/2clock) / 60.055 fps (1/4clock) / 360.33 fps (3/2clock)	
Pixel frequency		24.5454 MHz (Normal) / 12.2727 MHz (1/2clock) / 6.13635 MHz (1/4clock) / 36.818 MHz (3/2clock)	
Video output		<u>8bit</u> / 10bit / 12bit *Note2	
Minimum scene illumination *2		7.14lx at F1.2	0.07lx at F1.2
Sync. System		Internal	
Electronic shutter		Auto / Manual (software selectable)	
	Normal	1/36,818,182 to 1/22.40 seconds(default 1/29.18 seconds)	
	1/2 clock	1/18,409,091 to 1/11.20 seconds	
	1/4 clock	1/9,204,545 to 1/5.60 seconds	
Gain		Auto / Manual (software selectable, default: x3.55)	
Gamma		Manual (software selectable, default: 1)	
White balance		Auto / Manual / One shot (software selectable)	-
Trigger mode		Free-run / Edge preset trigger / Pulse width trigger / Start & stop trigger (software selectable) (Hardware and Software trigger are available)	
Camera Reset		Support on Pin 5	
LED Status		Green(Flicker):Power-On, Green: Camera works	
Pixel Blemish Correction		64 Points (default: off)	
Input/output		USB2.0 High speed	
Power	Input voltage	+5 V through USB connector (+4.4 to +5.25V)	
	Consumption	< 2.0 W *3	

2.1.2 Mechanical Specifications

		STC-SC33USB / STC-SB33USB
Dimensions		Board Type::36(W) x 36(H) x 15.3(D) CS-Mount(without USB connector)
Lens mount		CS mount / MicroLens Mount (M12 P0.5) / None Mount
Weight		Approx. 15g
Interface connector	Angle	USB: mini-B USB connector IO Connector : SM05B-SRSS-TB (JST) 5pin

2.1.3 Environmental Specifications

		STC-SC33USB / STC-SB33USB
Operational temperature		0 to 40 deg. C
Storage temperature		-30 to 65 deg. C
Vibration *4		20Hz to 200Hz to 20Hz (5min./cycle), acceleration 10G, 3 directions 30 min. each
Shock *4		Acceleration 70G, half amplitude 6ms, 3 directions 3 times each
Standard compliancy		Case Type: EMS: EN61000-6-2, EMI: EN55011
RoHS		RoHS compliance

*1: [Default setting of Maximum Frame Rate]

Bold: On Sentech Viewing software (StcamSWare)

*2: As for the 10,12bit output, clock speed should be slowed in order to obtain the correct frame rate.

*3: Power consumption could be higher than this number when used in partial scan mode at 90 fps.

*4: Lens: COSMICAR/PENTAX,C1614-M with C-Adaptor.

2.1.4 Spectral Sensitivity Characteristics

STC-SC33USB (with IR cut filter)

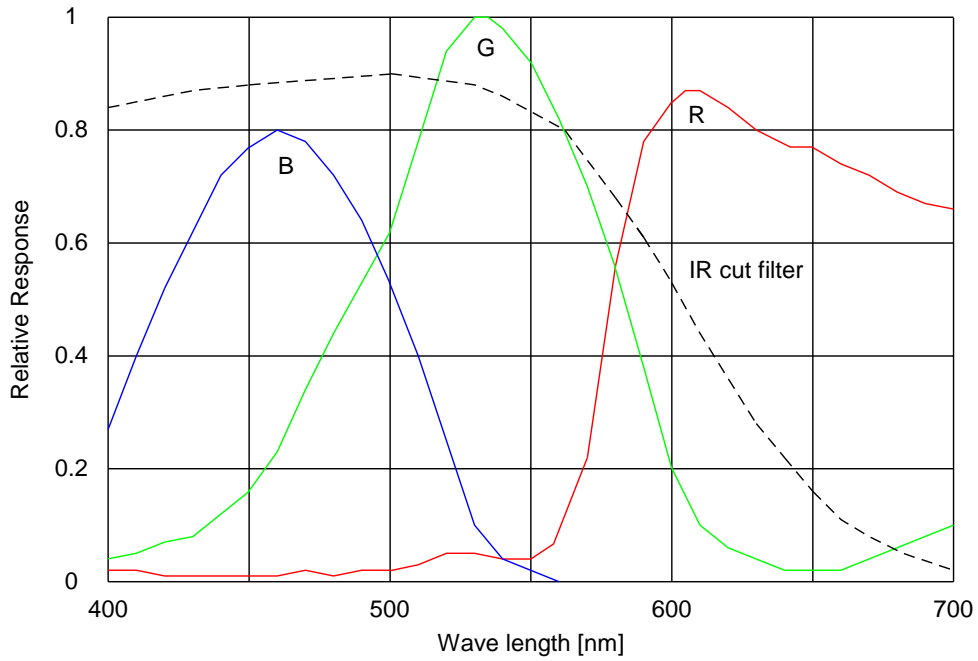

STC-SB33USB

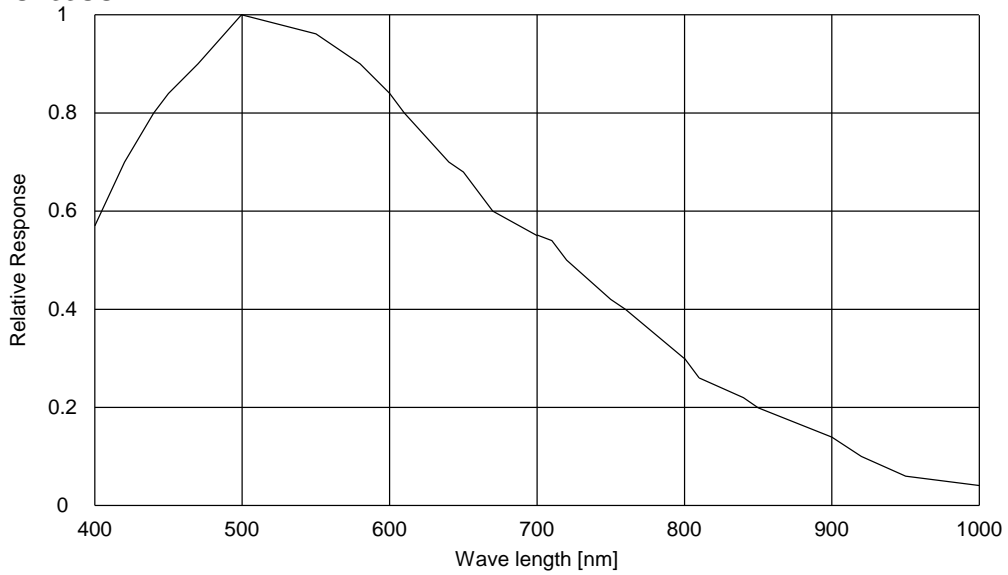

2.2 STC-SC83USB / STC-SB83USB

2.2.1 Electronic Specifications

		STC-SC83USB	STC-SB83USB
Image Sensor		1/3" interline XGA color progressive CCD: ICX204AK (Sony)	1/3" interline XGA B/W progressive CCD: ICX204AL (Sony)
Total picture elements		1077 (H) x 788 (V)	
Effective picture elements		1034 (H) x 779 (V)	
Chip size		5.80 (H) x 4.92 (V) mm	
Cell size		4.65 (H) x 4.65 (V) μm	
Scanning system		Progressive	
Resolution		1024 (H) x 768 (V) (Full scanning) 1024 (H) x 344 (V) (1/2 partial scanning) 1024 (H) x 136 (V) (1/4 partial scanning)	
Scanning methods		Full scanning, 1/1 partial scanning, 1/2 partial scanning, 1/4 partial scanning, Variable partial scanning	Full scanning, 1/1 partial scanning, 1/2 partial scanning, 1/4 partial scanning, Variable partial scanning, Binning scanning, Binning 1/1 partial scanning, Binning 1/2 partial scanning, Binning 1/4 partial scanning, Binning variable partial scanning
Max.	Full scanning	29.18 fps (Normal) / 14.59 fps (1/2 clock) / 7.295 fps (1/4 clock)	
Frame	1/2 partial scanning	60.02 fps (Normal) / 30.01 fps (1/2 clock) / 15.00 fps (1/4 clock)	
Rate	1/4 partial scanning	120.35 fps (Normal) / 60.175 fps (1/2 clock) / 30.087 fps (1/4 clock)	
Pixel frequency		29.5 MHz (Normal) / 14.75 MHz (1/2 clock) / 7.375 MHz (1/4 clock)	
Video output		8bit / 10bit / 12bit *1	
Minimum scene illumination		16.54lx at F1.2	0.31lx at F1.2
Sync. System		Internal	
Electronic shutter		Auto / Manual (software selectable)	
Normal		1/36,818,182 to 1/22.40 seconds(default 1/29.18 seconds)	
1/2 clock		1/18,409,091 to 1/11.20 seconds	
1/4 clock		1/9,204,545 to 1/5.60 seconds	
Gain		Auto / Manual (software selectable, default: x3.55)	
Gamma		Manual (software selectable, default: 1)	
White balance		Auto / Manual / One shot (software selectable)	-
Trigger mode		Free-run / Edge preset trigger / Pulse width trigger / Start & stop trigger (software selectable) (Hardware and Software trigger are available)	
Camera Reset		Support on Pin 5	
LED Status		Green(Flicker): Power-On, Green: Camera works	
Pixel Blemish Correction		64 Points	
Input/output		USB2.0 High speed	
Power	Input voltage	+5 V through USB connector (+4.4 to +5.25V)	
	Consumption	< 1.4W	

2.2.2 Mechanical Specifications

		STC-SC83USB / STC-SB83USB
Dimensions		Board Type::36(W) x 36(H) x 15.3(D) CS-Mount(without USB connector)
Lens mount		CS mount / MicroLens Mount (M12 P0.5) / None Mount
Weight		Approximately 15g
Interface connector	Angle	USB: mini-B USB connector IO Connector : SM05B-SRSS-TB (JST) 5pin

2.2.3 Environmental Specifications

		STC-SC83USB / STC-SB83USB
Operational temperature		0 to 40 deg. C
Storage temperature		-30 to 65 deg. C
Vibration	*2	20Hz to 200Hz to 20Hz (5min./cycle), acceleration 10G, 3 directions 30 min. each
Shock	*2	Acceleration 70G, half amplitude 6ms, 3 directions 3 times each
Standard compliancy		Case Type: EMS: EN61000-6-2, EMI: EN55011
RoHS		RoHS compliance

*Note1: As for the 10,12bit output, clock speed should be slowed in order to obtain the correct frame rate.

*Note2: Lens: COSMICAR/PENTAX,C1614-M with C-Adaptor.

2.2.4 Spectral Sensitivity Characteristics

STC-SC83USB (with IR cut filter)

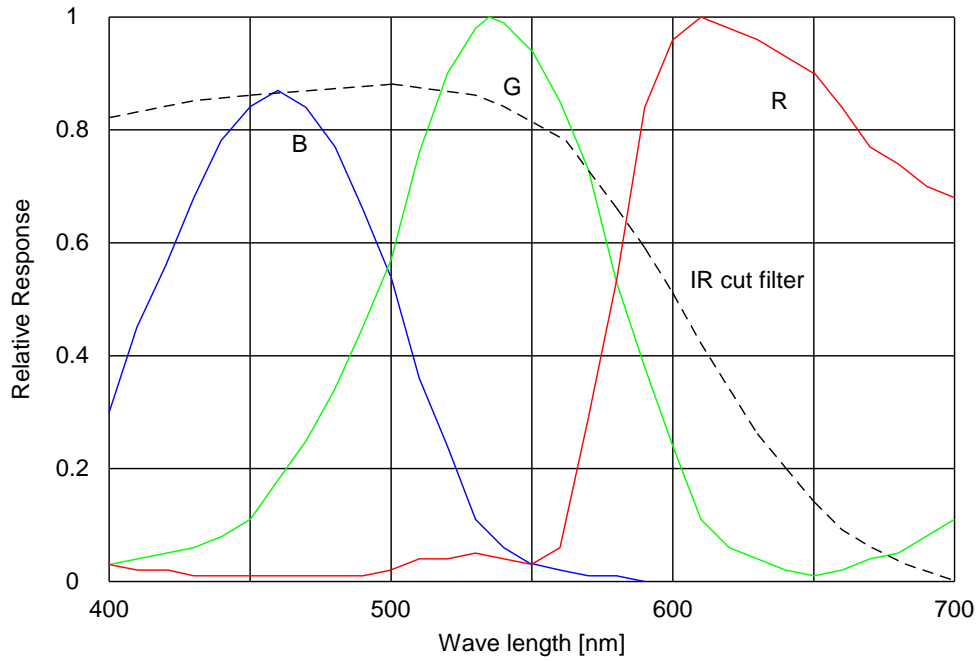

STC-SB83USB

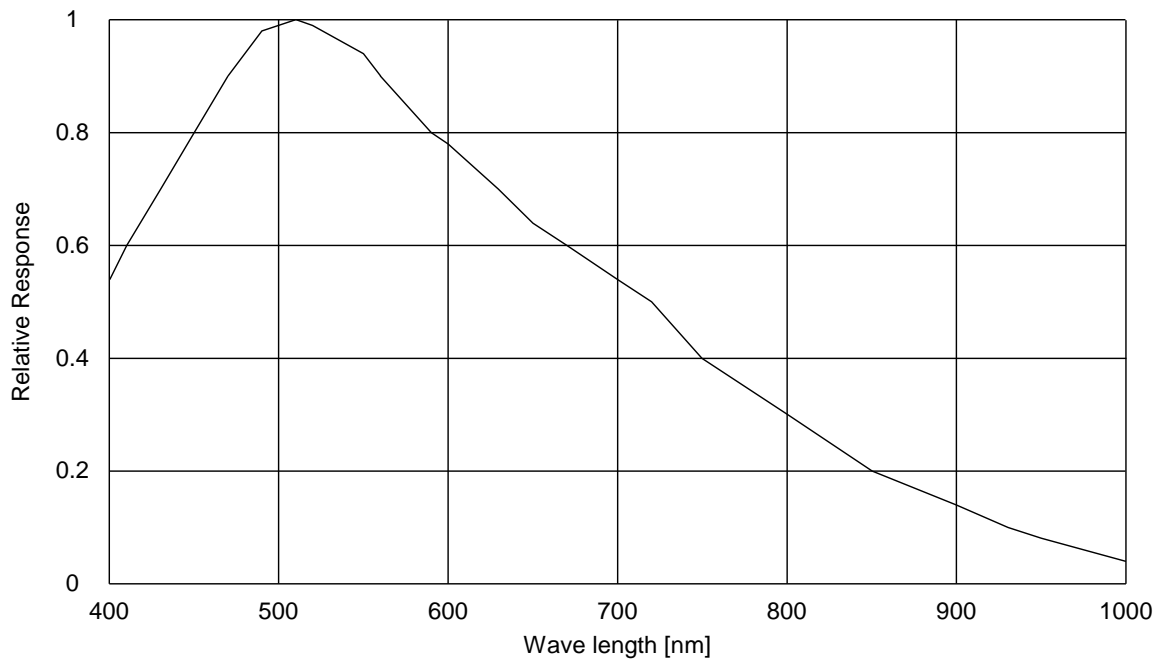

2.3 STC-SC133USB / STC-SB133USB

2.3.1 Electronic Specifications

Product		STC-SC133USB	STC-SB133USB
Image Sensor		1/3" interline 1.3MP color progressive CCD: ICX445AQ (Sony)	1/3" interline 1.3MP B/W progressive CCD: ICX445AL (Sony)
	Total picture elements	1348 (H) x 976 (V)	
	Effective picture elements	1296 (H) x 966 (V)	
	Chip size	6.26 (H) x 5.01 (V) mm	
	Cell size	3.75 (H) x 3.75 (V) μm	
	Scanning system	Progressive	
Resolution		1280 (H) x 960 (V) (Full scanning) 1280 (H) x 440 (V) (1/2 partial scanning) 1280 (H) x 168 (V) (1/4 partial scanning)	
Scanning methods		Full scanning, 1/1 partial scanning, 1/2 partial scanning, 1/4 partial scanning, Variable partial scanning	Full scanning, 1/1 partial scanning, 1/2 partial scanning, 1/4 partial scanning, Variable partial scanning, Binning scanning, Binning 1/1 partial scanning, Binning 1/2 partial scanning, Binning 1/4 partial scanning, Binning variable partial scanning
Max.	Full scanning	22.40 fps (Normal) / 11.20 fps (1/2 clock) / 5.60 fps (1/4 clock)	
Frame	1/2 partial scanning	44.81 fps (Normal) / 22.40 fps (1/2 clock) / 11.20 fps (1/4 clock)	
Rate	1/4 partial scanning	89.80 fps (Normal) / 44.90 fps (1/2 clock) / 22.45 fps (1/4 clock)	
Pixel frequency		36.818 MHz (Normal) / 18.409 MHz (1/2 clock) / 9.20453 MHz (1/4 clock)	
Video output		8bit / 10bit / 12bit *1	
Minimum scene illumination *2		8.09lx at F1.2	0.09lx at F1.2
Sync. System		Internal	
Electronic shutter		Auto / Manual (software selectable)	
	Normal	1/36,818,182 to 1/22.40 seconds (default: 1/22.40 seconds)	
	1/2 clock	1/18,409,091 to 1/11.20 seconds	
	1/4 clock	1/9,204,545 to 1/5.60 seconds	
Gain		Auto / Manual (software selectable, default: x3.55)	
Gamma		Manual (software selectable, default: 1)	
White balance		Auto / Manual / One shot (software selectable)	-
Trigger mode		Free-run / Edge preset trigger / Pulse width trigger / Start & stop trigger (software selectable) (Hardware and Software trigger are available)	
Camera Reset		Support on Pin 5	
LED Status		Green(Flicker):Power-On, Green: Camera works	
Pixel Blemish Correction		64 Points	
Input/output		USB2.0 High speed	
Power	Input voltage	+5 V through USB connector (+4.4 to +5.25V)	
	Consumption	< 1.5W	

2.3.2 Mechanical Specifications

		STC-SC133USB / STC-SB133USB
Dimensions		Board Type::36(W) x 36(H) x 15.3(D) CS-Mount(without USB connector)
Lens mount		CS mount / MicroLens Mount (M12 P0.5) / None Mount
Weight		Approx. 16g
Interface connector	Angle	USB: mini-B USB connector IO Connector : SM05B-SRSS-TB (JST) 5pin

2.3.3 Environmental Specifications

		STC-SC133USB / STC-SB133USB
Operational temperature		0 to 40 deg. C
Storage temperature		-30 to 65 deg. C
Vibration	*2	20Hz to 200Hz to 20Hz (5min./cycle), acceleration 10G, 3 directions 30 min. each
Shock	*2	Acceleration 70G, half amplitude 6ms, 3 directions 3 times each
Standard compliancy		Case Type: EMS: EN61000-6-2, EMI: EN55011
RoHS		RoHS compliance

*Note1: As for the 10,12bit output, clock speed should be slowed in order to obtain the correct frame rate.

*Note2: Lens: COSMICAR/PENTAX,C1614-M with C-Adaptor.

2.3.4 Spectral Sensitivity Characteristics

STC-SC133USB (with IR cut filter)

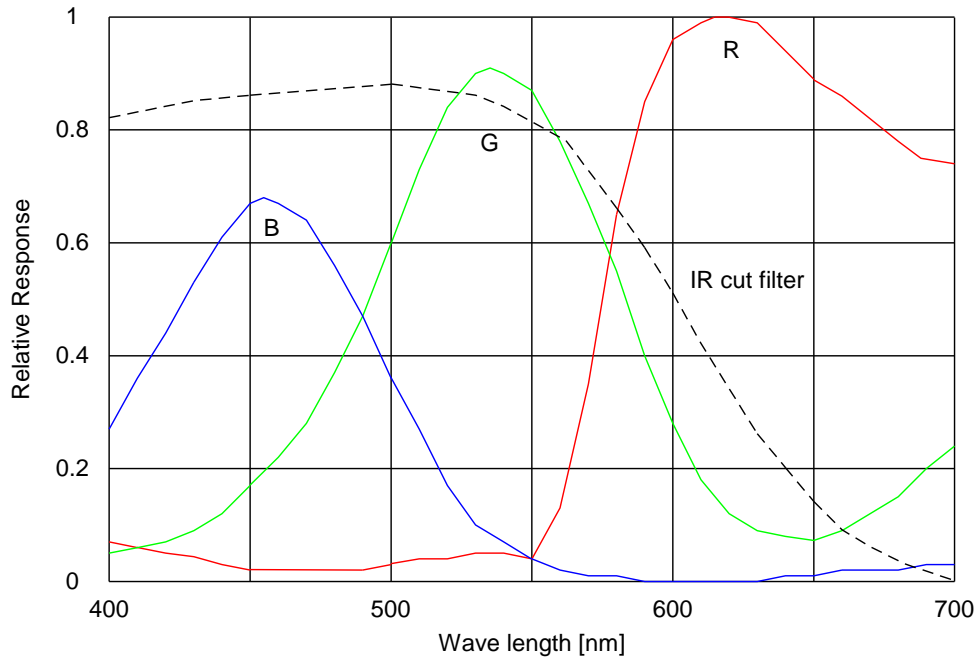

STC-SB133USB

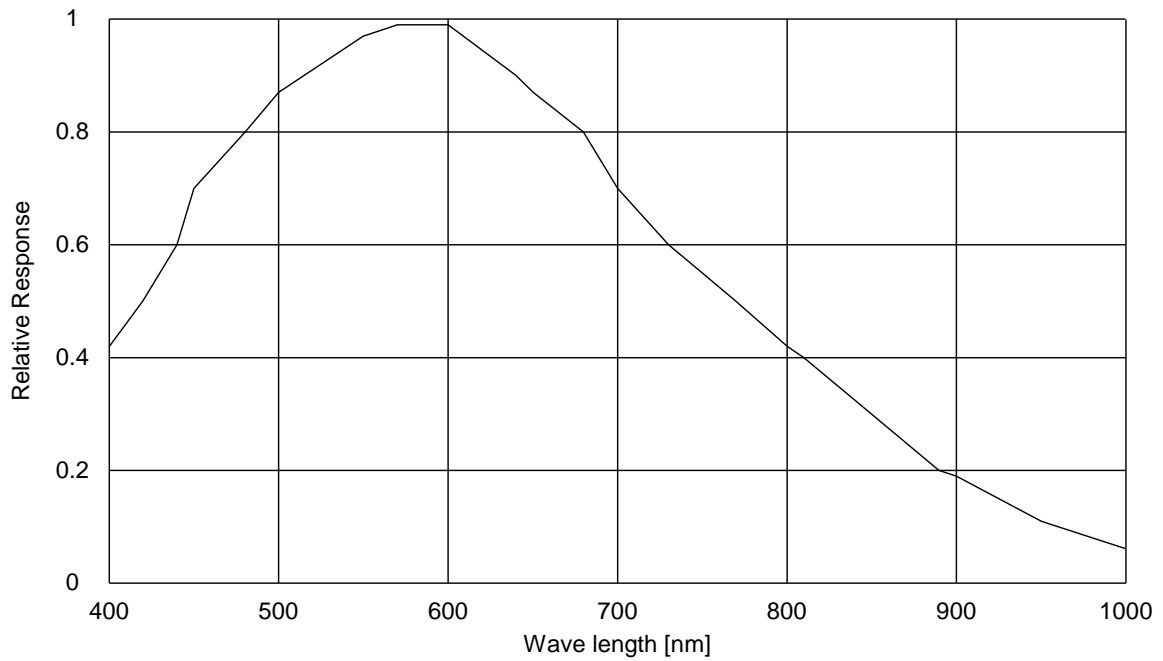

3 Interface Connector Specifications (Board Type)

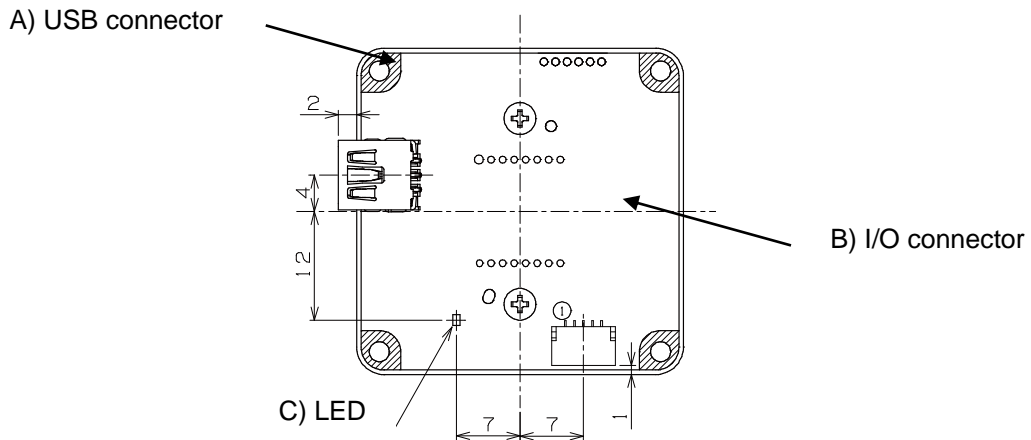

- A) USB connector: Mini-B USB type
- B) I/O connector: Angle : SM05B-SRSS-TB (JST) 5pin or equivalent
 Straight (Option): BM05B-SRSS-TB (JST) 5pin or equivalent
 Angle : SM05B-SRSS-TB (JST) 5pin or equivalent
 This connector is used for the input and output signals.
 Trigger input and the output signals can be assigned through the camera setting communication.
The power in the connector is for the input / output signals, NOT for the camera power.

Pin assignment

Pin	Singal	Function	IO	Electric Specification	Default
1	IO_GND	IO GND	-	IO GND	-
2	IO_VCC	IO Power	IN	+2.0 to 5.0Vdc	-
3	IO_OUT	Camera Output	OUT		No-Function
4	IO_IN	Camera Input	IN		No-Function
5	RST	Camera Reset	IN		Enable

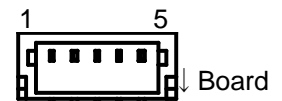

[Side View]

Input and output signals are isolated.

- C) LED Green (Flicker) : Power-ON
 Green: Camera is working

4 Input / Output signals specifications

4.1 Input signals specifications

4.1.1 Function for the input signals

The input signals (IN1) can be configured through the software using the following functions:

No.	Functions	Polarity
1	No signal (Default)	-
2	General input	-
3	Trigger signal input	Positive / Negative

The polarity for the trigger signal input can be selected.

4.1.2 Characteristics of the input signals

Input signal level: High: IO VCC IN (+2.0 to +5.0V)

Low: Smaller than 0.8V

Hardware trigger pulse width: more than 0.1 usec

4.1.3 Input signal circuit (Including reset signal)

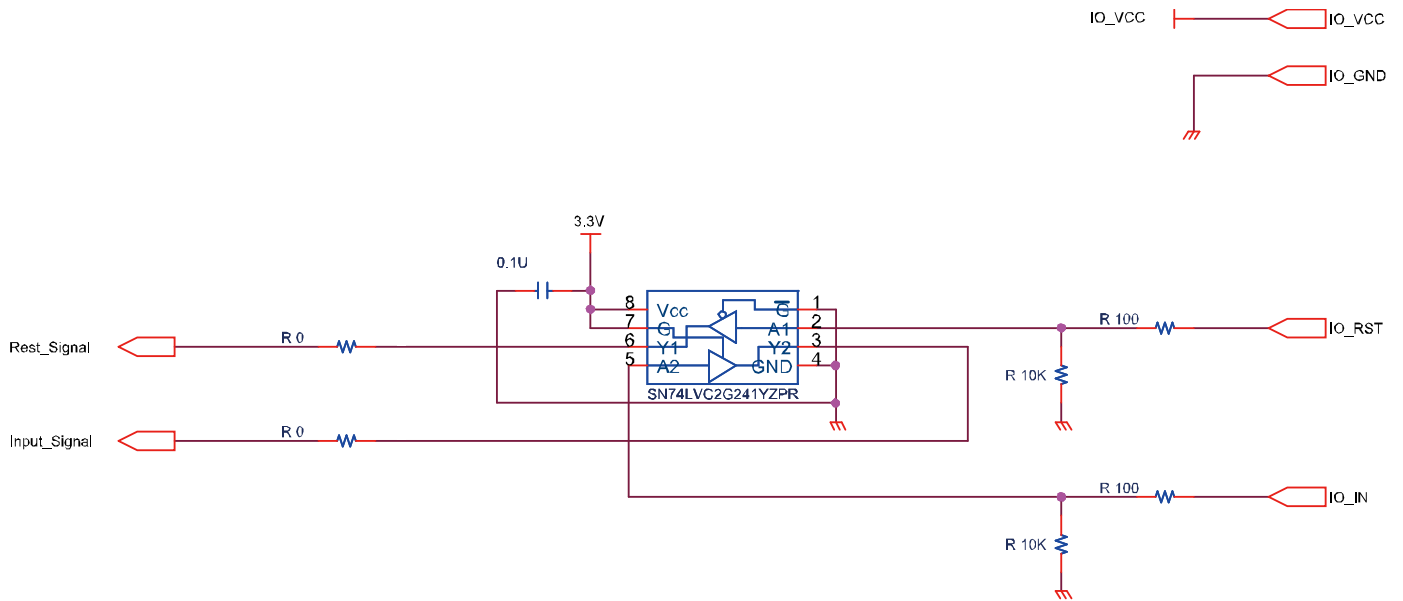

4.1.4 Reset signal

The camera will be reset after 5 seconds high signal on Pin 5.

4.2 Output signals specifications

4.2.1 Function for the output signals

The following functions can be configured for the output signals (OUT) through the software on Pin 3.

No.	Functions	Polarity
1	No signal (Default)	-
2	General output	-
3	Trigger signal output	Positive / Negative
4	Exposure end signal output	Positive / Negative
5	CCD read out end signal output	Positive / Negative
6	Strobe signal output (Time setting)	Positive / Negative
7	Strobe signal output (Exposure time)	Positive / Negative

The polarity for the trigger signal, the exposure end signal, the CCD read out end signal, the strobe signal (time setting) and the strobe signal (exposure time) can be selected.

4.2.2 Characteristics of the output signals

Output signal level: High: IO VCC IN (+3.0 to +26.4V)
Low: Smaller than 0.8V

Output signal duration: The signal duration should be longer than “Tf + Tr”.
Please check “Output signal response timings” for Tf and Tr.
The signal duration can be adjusted by the software.

Output signal response timings:

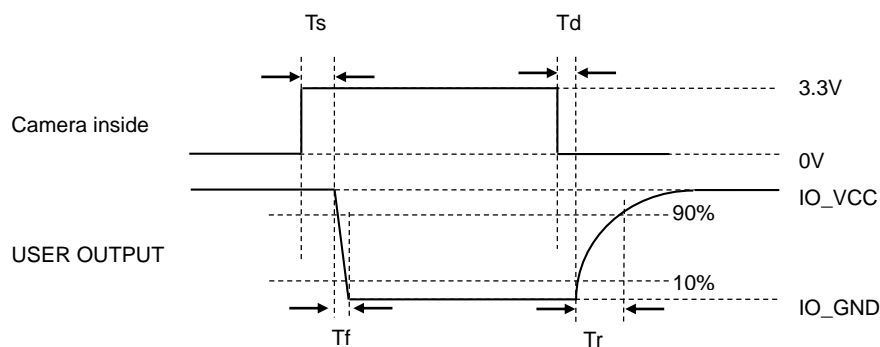

	IO_VCC			
	3.3[V]	5.0[V]	12[V]	24[V]
Td	2.80 [us]	2.76 [us]	2.72 [us]	2.54 [us]
Tr	1.86 [us]	1.95 [us]	1.74 [us]	1.95 [us]
Ts	0.07 [us]	0.07 [us]	0.08 [us]	0.08[us]
Tf	0.06[us]	0.07 [us]	0.12 [us]	0.18 [us]

4.2.3 Output signal circuit

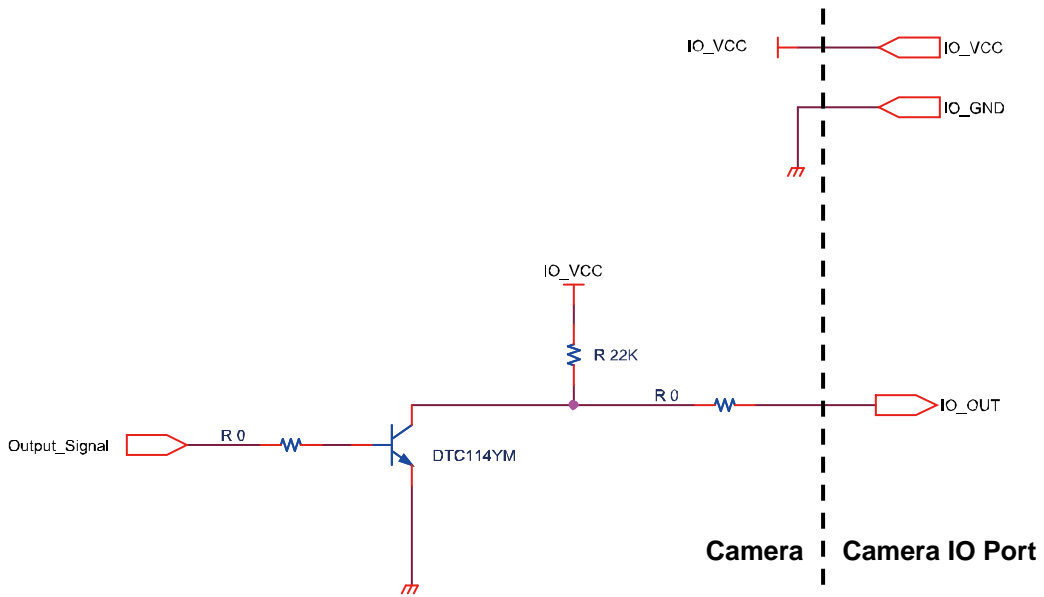

5 Dimensions

5.1 STC-SCxxxUSB-BxCS (Color, Board Type, CS-Mount, USB Angle/Straight)

USB Angle connector

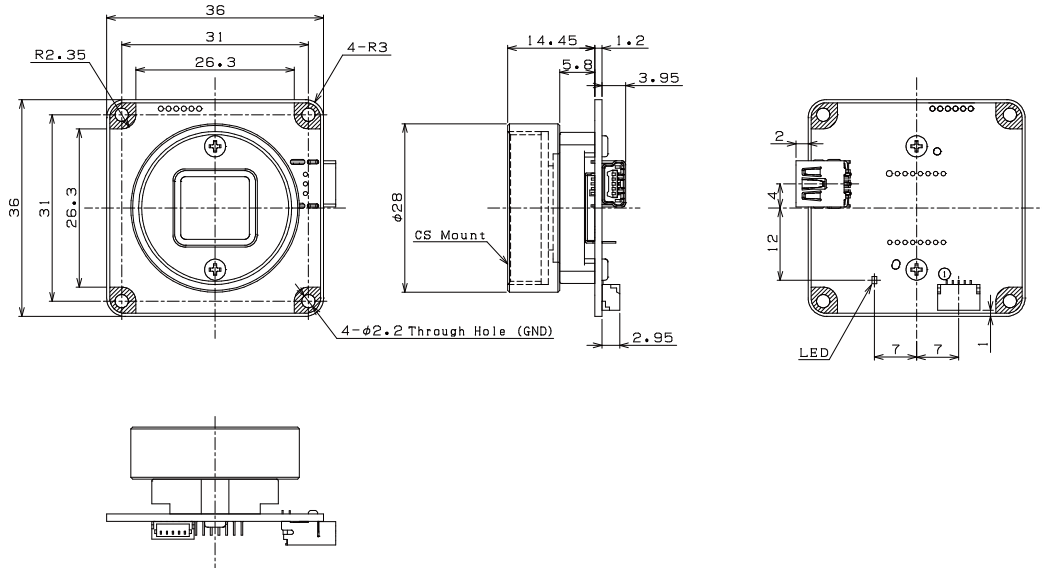

USB Straight connector

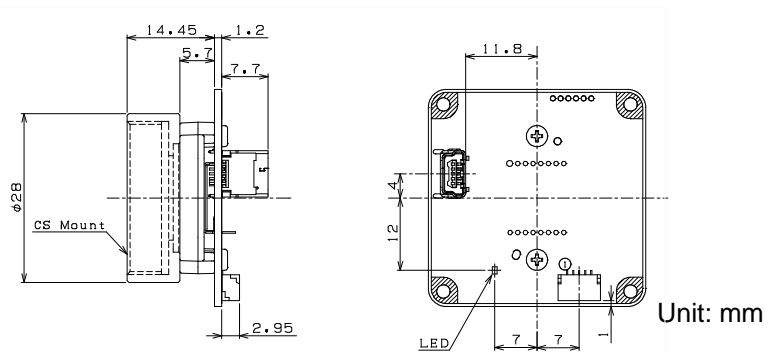

5.2 STC-SBxxxUSB-BLCS (Monochrome, Board Type, CS-Mount, USB Angle/Straight*)

*Note: For the dimensions of the Straight Connector, please refer to section 5.1.

USB Angle connector

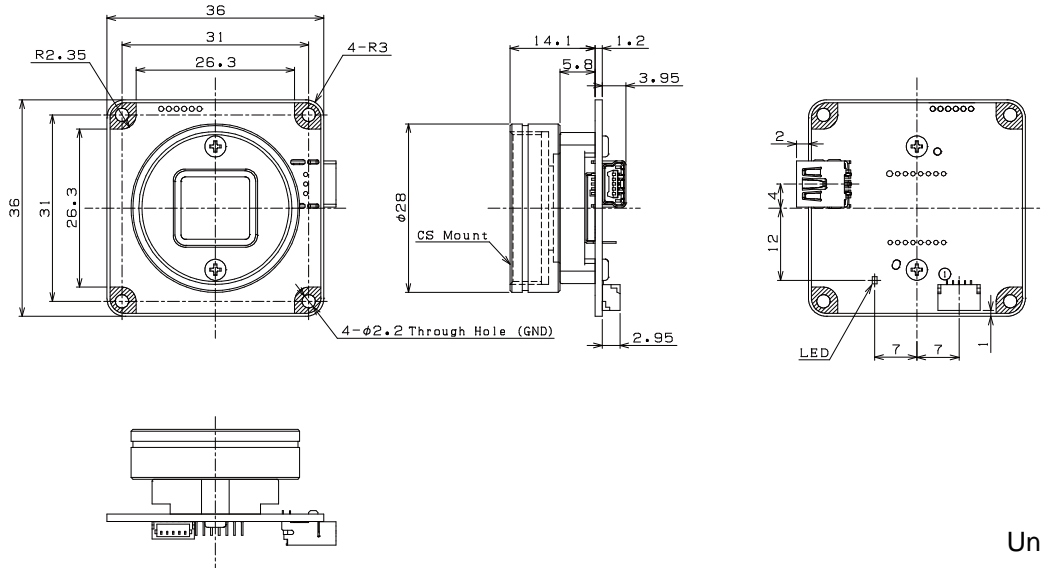

5.3 STC-SCxxxUSB-BL / STC-SBxxxUSB-BL (Color / Monochrome, Board Type, No-Mount, USB Angle/Straight*)

*Note: For the dimensions of the Straight Connector, please refer to section 5.1.

USB Angle connector

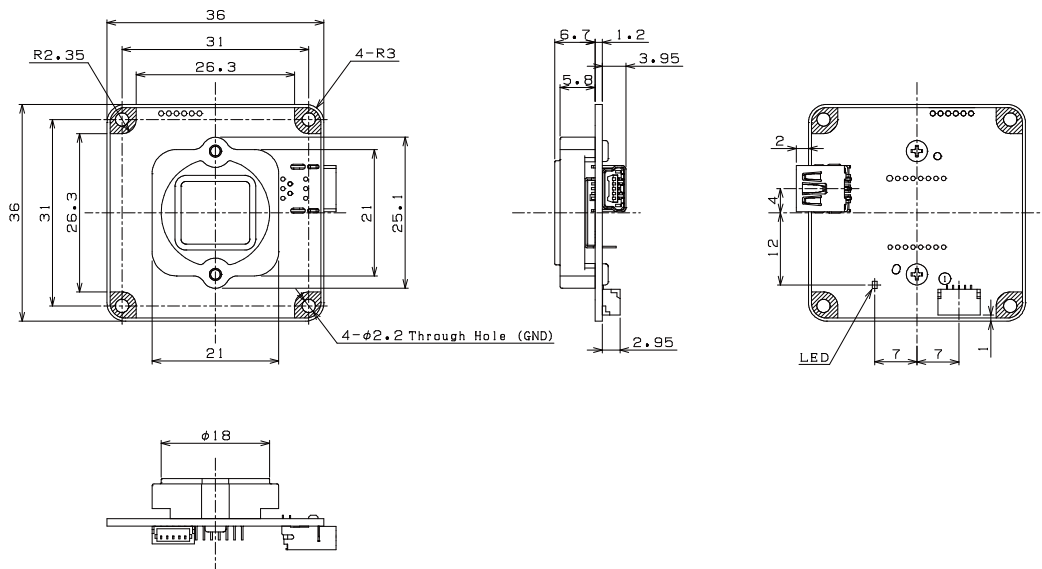

5.4 STC-SCxxxUSB-BLL (Color, Board Type, Fixed Focus, USB Angle/Straight*)

*Note: For the dimensions of the Straight Connector, please refer to section [5.1](#).

USB Angle connector

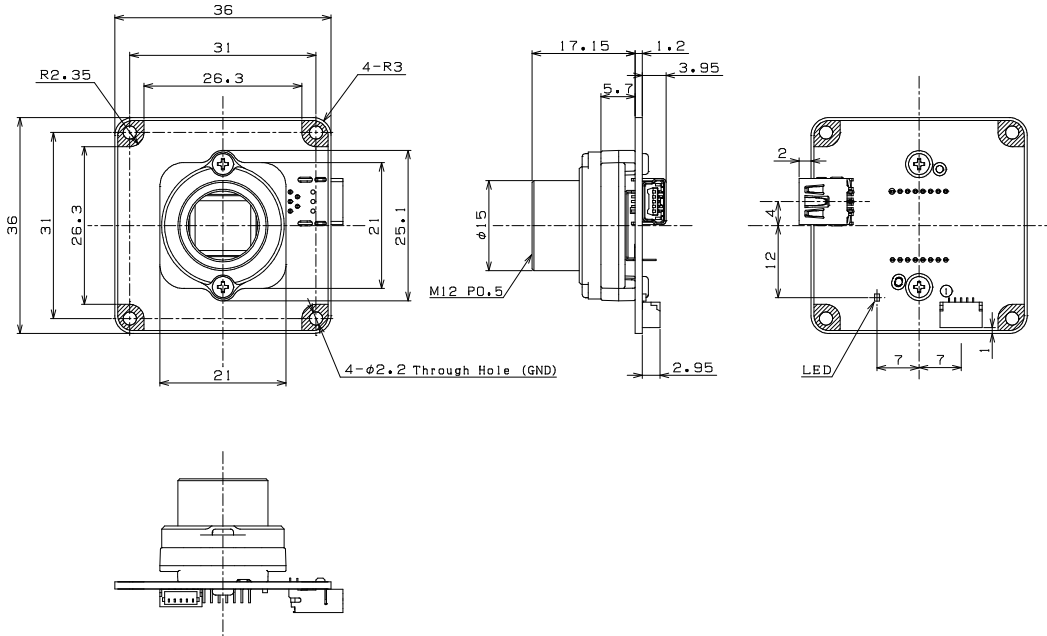

Unit: mm

5.5 STC-SBxxxUSB-BLL (Monochrome, Board Type, Fixed Focus, USB Angle/Straight*)

*Note: For the dimensions of the Straight Connector, please refer to section [5.1](#).

USB Angle connector

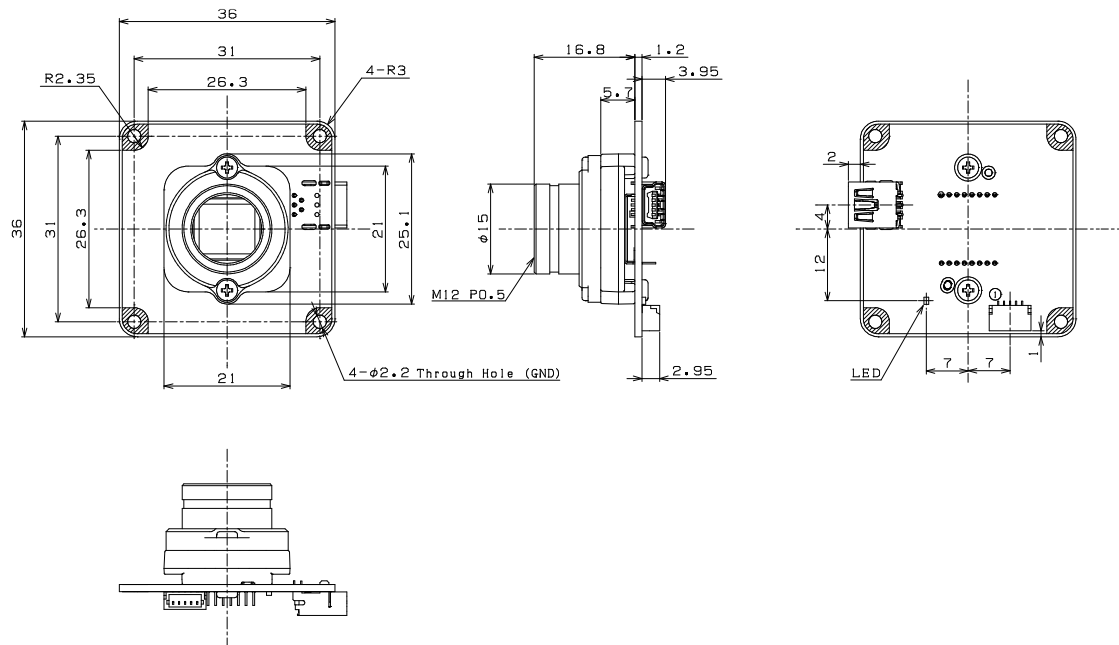

Unit: mm

5.6 STC-SCxxxUSB-AL / STC-SBxxxUSB-AL (Color/Monochrome, Cased Type, CS-Mount*)

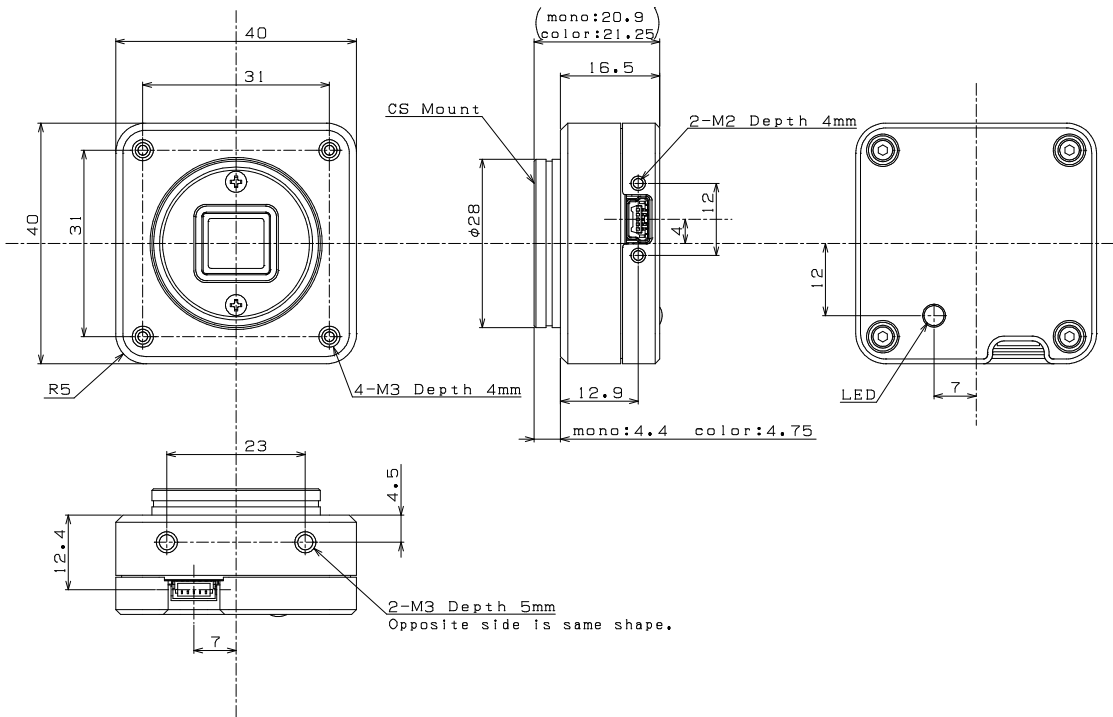

Unit: mm

6 Revisions

Rev	Date	Changes	Note
1.00	2013/08/23	New document	
1.01	2013/09/13	Revised: Minimum scene illumination	
1.02	2013/11/25	Revised: IO port description	
1.03	2013/11/29	Revised: Added USB straight connector information	
1.04	2014/01/17 2014/02/19	Revised: Added cased type model, Added explanation around IO port(IO table and Trigger Pulse) Revised -ALCS ->---AL on cased type	
1.05	2014/03/12	Revised: Replaced the drawing of -BxL model Created new English version of Specifications	

7F, Harada center building
9-17, Naka cho 4 chome
Atsugi-city, Kanagawa
243-0018 Japan

Sensor Technology Co., Ltd

TEL +81-46-295-7061 FAX +81-46-295-7066
URL <http://www.sentech.co.jp/>