

ET8122Pp-S-DR

Industrial Unmanaged 8-port 10/100Base-TX (PoE+) + 2-port 10/100/1000Base-TX/SFP Combo Ethernet Switch



Features

- ▶ 8 10/100Base-TX + 2 10/100/1000Base-TX/SFP Combo with PoE+ / PSE
- ▶ Support IEEE802.3at PoE+ (30W per port)
- ▶ RJ45 Port Supports 10/100Mbps-Full/Half-duplex, Auto-negotiation, Auto MDI/MDIX
- ▶ Combo RJ45 Port Supports 10/100/1000Mbps-Full/Half-duplex, Auto-negotiation, Auto MDI/MDIX
- ▶ Supports external SFP
- ▶ Supports 802.3x Flow control
- ▶ Supports 4K MAC address
- ▶ 1M bits frame buffer memory
- ▶ Redundant Power Inputs
- ▶ Supports DIN-Rail and Wall-mount installation
- ▶ -10°C to 60°C (14°F to 140°F) operating temperature



Warranty

- ▶ 5-Year Warranty

Typical Application

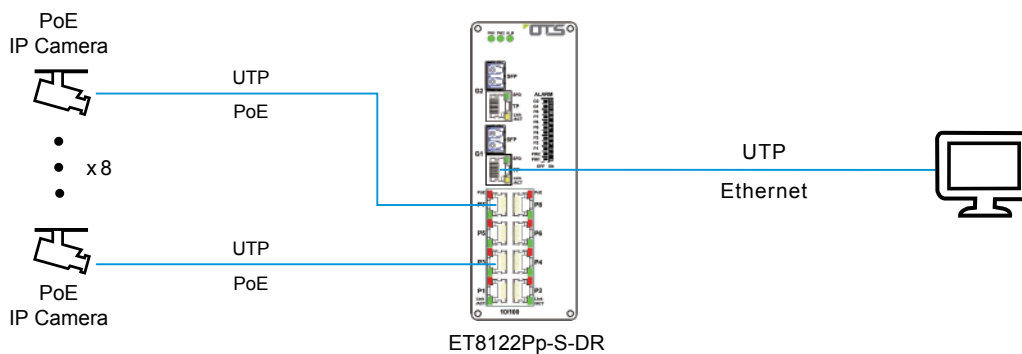

Specifications

Ethernet

Standards	IEEE802.3 10Base-T IEEE802.3u 100Base-TX IEEE802.3ab 1000Base-T IEEE802.3z 1000Base-X IEEE802.3af/at Power over Ethernet
Processing Type	Store-and-Forward
Switch Fabric	5.6 Gbps
Forward Filter Rate	14,880pps (10Mbps) 148,800pps (100Mbps) 1,488,000pps (1000Mbps)
Packet Buffer Memory	2.75 Mbit
Max Packet Length	1536 Bytes
Address Table Size	4K MAC Addresses
Connector	10 x RJ45
Optical Port	2 x SFP 1000Base-FX

Electrical and Mechanical

Input Power	48~57VDC, Redundant Power Input (6-pin Terminal Block)
Power Consumption	Max. 253W

Specifications

LED Indicators	
Power	Power Status
Ethernet (per port)	Link/Activity, Speed
SFP (per port)	Link/Activity
ALM	Power or Port Fail
PoE	
Standard	IEEE802.3at
Port	RJ45 Port 1~Port 8
Per Port Power	30W (Alternative B Mode)
Dimensions (W x D x H)	59 x 120.5 x 165 mm
Weight	1.0 Kg
Casing	Aluminum Case
Mounting options	DIN Rail / Wall Mount

Environmental

Operating Temperature	-10°C to 60°C (14°F to 140°F)
Storage Temperature	-40°C to 85°C (-40°F to 185°F)
Relative Humidity	5% to 95% non-condensing
MTBF	> 200,000 hrs

Regulatory Approvals

ISO9001, CE, FCC, RoHS

EMI

EN55022:2010+AC: 2011, Class A

EN 61000-3-2: 2006+A1: 2009+A2: 2009

EN 61000-3-3: 2013

EN55024:2010

EMS

IEC 61000-4-2: 2008 (ESD)

IEC 61000-4-3: 2010 (RS)

IEC 61000-4-4: 2012 (EFT)

IEC 61000-4-5: 2014 (Surge)

IEC 61000-4-6: 2013 (CS)

IEC 61000-4-8: 2009 (PFMF)

Ordering Information

Available Model	Description
ET8122Pp-S-DR	Industrial Unmanaged 8-port 10/100Base-TX (PoE+) + 2-port 10/100/1000Base-TX/SFP Combo Ethernet Switch

Optional Accessories (to be purchased separately)

SFP	(S)=SFP Option. Please select your SFP on our SFP Modules page at the back of the catalogue or our website www.ot-systems.com for details.
Power supply	Please refer to the power supply information at the back of the catalogue, our website www.ot-systems.com , or consult OTS sales at sales@ot-systems.com for your power system design properly.

Package Checklist

■ Unmanaged PoE Switch	x 1
■ Wall Mount plates	x 1
■ Din Rail Clip	x 1
■ Quick Installation Guide	x 1



OT Systems Ltd., January 2016

Due to continuous improvement, all product specifications are subject to change without further notice.