

# SENTECH

**STC-CMC2MPOE (2Meg, Color)**  
**STC-CMB2MPOE (2Meg, B/W)**  
**STC-CMB2MPOE-IR (2Meg, Near IR)**  
**STC-CMC4MPOE (4Meg, Color)**  
**STC-CMB4MPOE (4Meg, B/W)**  
**STC-CMB4MPOE-IR (4Meg, Near IR)**

GigE Vision POE CMOS  
Color / Monochrome Camera  
Product Specifications

## Safety Precautions

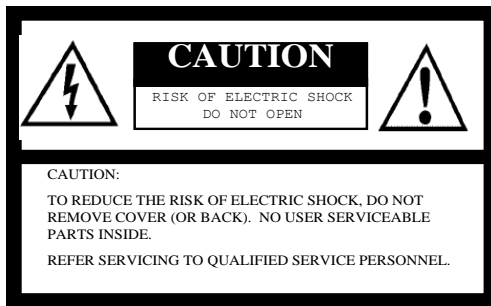

For U.S.A.

Warning:

This equipment generates and uses radio frequency energy and if not installed and used properly, I.e., in strict accordance with the instruction manual, may cause harmful interference to radio communications. It has been tested and found to comply with the limits for a Class A computing device pursuant to Subpart J of Part 15 of FCC Rules, which are designed to provide reasonable protection against such interference when operated in a commercial environment.

For Canada

Warning:

This digital apparatus does not exceed the Class A limits for radio noise emissions from digital apparatus set out in the Radio Interference Regulations of the Canadian Department of Communications.



The lightning flash with arrowhead symbol, within an equilateral triangle, is intended to alert the user to the presence of uninsulated “dangerous voltage” within the product’s enclosure that may be of sufficient magnitude to constitute a risk of electric shock to persons.



The exclamation point within an equilateral triangle is intended to alert the user to the presence of important operating and maintenance (servicing) instructions in the literature accompanying the appliance.

WARNING:

TO PREVENT FIRE OR SHOCK HAZARD, DO NOT EXPOSE THIS APPLIANCE TO RAIN OR MOISTURE.

## Product Precautions

- Handle the camera with care. Do not abuse the camera. Avoid striking or shaking it. Improper handling or storage could damage the camera.
- Do not pull or damage the camera cable.
- During camera use, do not wrap the unit in any material. This will cause the internal temperature of the unit to increase.
- Do not expose the camera to moisture, or do not try to operate it in wet areas.
- Do not operate the camera beyond its temperature, humidity and power source ratings.
- While the camera is not being used, keep the lens or lens cap on the camera to prevent dust or contamination from getting in the CCD or filter area and scratching or damaging this area.
- Do not keep the camera under the following conditions:
  - In wet, moist, and high humidity areas
  - Under hot direct sunlight
  - In high temperature areas
  - Near an object that releases a strong magnetic or electric field
  - Areas with strong vibrations
- Use a soft cloth to clean the camera. Use pressured air spray to clean the surface of the glass. DO not scratch the surface of the glass.

## Copyright & Disclaimer

Sensor Technologies America, Inc. (DBA Sentech America) believes the contents and specifications of its website, catalog, documentation and ads are correct; however, Sentech America provides no representation or warranty regarding such information or product(s) contained therein. It is requested that Sentech America be given appropriate acknowledgement in any subsequent use of such work by a third party.

While every effort has been made to ensure that the details contained in Sentech America's website and all documentation are correct and up-to-date, Sentech America assumes no liability, legal or otherwise for any errors in listings, specifications, part numbers, process, software or model applications. Sentech America reserves the right to change specifications, product descriptions, product quality, pricing and application at any time without prior written or oral notice. Any party using such information assumes all risk for any and all damaged caused to themselves, a third party and/or property by virtue of incorrect information and/or failure of these products. By installing and/or using a Sentech America software development kit or other similar product and/or information obtained from Sentech America's website, catalog, documentation or ads, you hereby accept and understand these stated terms and conditions.

## Contents

<b>I. Introduction</b> .....	<b>5</b>
<b>II. Specifications</b> .....	<b>6-10</b>
A. Electronic Specifications .....	6-7
1. STC-CMC2MPOE / STC-CMB2MPOE / STC-CMB2MPOE-IR.....	6
2. STC-CMC4MPOE / STC-CMB4MPOE / STC-CMB4MPOE-IR.....	7
B. Spectral Sensitivity Characteristics .....	8-9
1. STC-CMB2MPOE / STC-CMB4MPOE .....	8
2. STC-CMC2MPOE / STC-CMC4MPOE .....	8
3. STC-CMC2MPOE-IR / STC-CMC4MPOE-IR (Near IR Model).....	9
C. Mechanical Specifications.....	10
D. Environmental Specifications .....	10
<b>III. Connector Specifications</b> .....	<b>11-16</b>
A. RJ45 Connector .....	11
B. Power-I/O Connector.....	12-16
1. Equivalent Circuit for the Input Pin of the I/O Connector .....	15
2. Typical Input Circuit .....	16
3. Typical Output Circuit .....	16
<b>IV. Dimensions</b> .....	<b>17</b>

## I. Introduction

This document describes the specifications of the following cameras:

STC-CMC2MPOE	(2M Color)
STC-CMB2MPOE	(2M Monochrome)
STC-CMB2MPOE-IR	(2M Near IR)
STC-CMC4MPOE	(4M Color)
STC-CMB2MPOE	(4M Monochrome)
STC-CMB4MPOE-IR	(4M Near IR)

## A. Features

- CMOS (Global Shutter)
- GigE Interface
- Power over Ethernet Support

## B. Naming Method

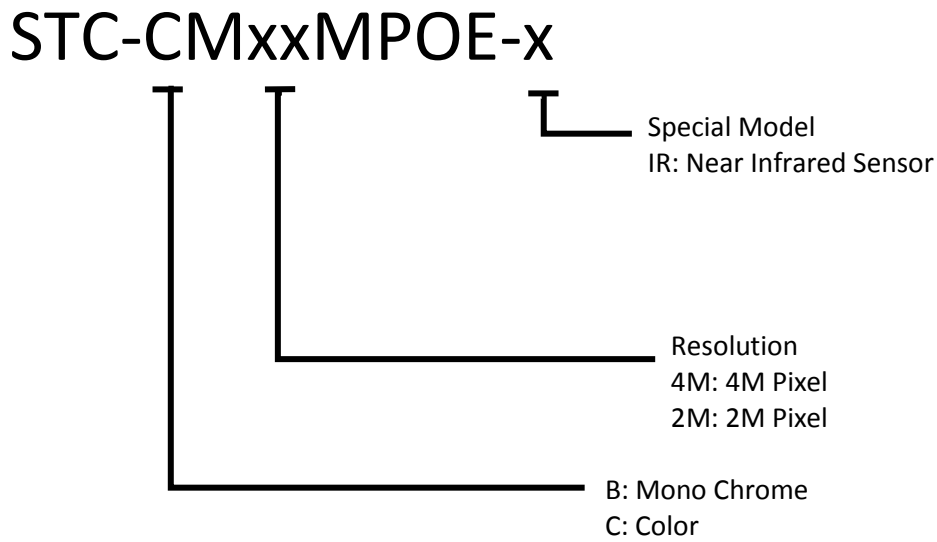

## II. Specifications

### A. Electronic Specifications

#### 1. STC-CMC2MPOE / STC-CMB2MPOE / STC-CMB2MPOE-IR

Product		STC-CMC2MPOE	STC-CMB2 MPOE
Imager		2/3" 2Meg color progressive CMOS (CMOSIS: CMV2000)	2/3" 2Meg monochrome progressive CMOS (CMOSIS: CMV2000)
Shutter Type		Global Shutter	Global Shutter
Total Picture Elements		2048 (H) x 1088 (V)	
Active Picture Elements		2048 (H) x 1088 (V)	
Cell Size		5.5 (H) x 5.5 (V) $\mu\text{m}$	
Scanning System		Progressive	
Vertical Frequency (Frame Rate)		50 Hz at full resolution (25Hz on 10bit for ether net bandwidth limitation) 1.00000 to 780 Hz adjustable via the communication (Frame rate depends on the AOI setting) Maximum frame rate (780 Hz) is when vertical resolution AOI setting is 32.	
Horizontal Frequency		58.1KHz (2TAP), 38.8KHz (1TAP)	58.1kHz
Pixel Frequency		150MHz (2TAP), 100MHz (1TAP)	150MHz
Noise Level	@ 8bit output	$\leq 3$ Digit (Gain 0 dB)	
	@ 10bit output	$\leq 12$ Digit (Gain 0 dB)	
Minimum Scene Illumination *Near IR (-NIR)		TBD Lux at F1.2 -	0.12 Lux at F1.2 0.09 Lux at F1.2
Sync. System		Internal	
Video Output Format		Digital 8, 10 bit Raw data or RGB 8 bit <b>(Default:8bit Raw)</b>	Digital 8, 10 bit Raw Data <b>(Default:8bit Raw)</b>
Interface		IEEE802.3 (1000BASE-T)	
Protocol		GigE Vision <sup>®</sup> 1.2 GenICam <sup>™</sup> 2.0	
Exposure Time		Preset continuous mode: 25 microseconds to 2000 milliseconds Preset trigger mode:25 microseconds to 2000 milliseconds Pulse width mode: 25 microseconds to 2000 milliseconds	
ALC (Automatic Light Control)		Automatic Exposure (AE) and Automatic Gain Control (AGC) (ON/OFF) (adjustable via the communication) <b>(Default: AE OFF, AGC ON)</b>	
Gain		x1 to x3 <b>(Default: x1)</b>	
Gamma		Gamma 1.0 (Factory default) or uploadable gamma table <b>(Default:1)</b>	
AOI Function		Variable AOI setting via the communication	
Color Interpolation		Available on RGB Output <b>(Default:ON)</b>	N/A
White Balance		Auto, Manual, Push to Set White Balance are available on both raw data and RGB outputs <b>(Default:OFF)</b>	N/A
Operational Mode		Edge preset trigger, Pulse width trigger <b>(Default:OFF)</b>	
Communication		UART communication through Ethernet port	
I/O		One opt-isolated input and two open collector outputs(+3.3V)	
Power	Input Voltage	+10.8 to +26.4 Vdc	
	Consumption (Max/Default)	Less than TBD W	

## 2. STC-CMC4MPOE / STC-CMB4MPOE / STC-CMB4MPOE-IR

Product		STC-CMC4MPOE	STC-CMB4MPOE
Imager		1" 4Meg color progressive CMOS (CMOSIS: CMV4000)	1" 4Meg monochrome progressive CMOS (CMOSIS: CMV4000)
Shutter Type		Global Shutter	Global Shutter
Total Picture Elements		2048 (H) x 2048 (V)	
Active Picture Elements		2048 (H) x 2048 (V)	
Cell Size		5.5 (H) x 5.5 (V) $\mu\text{m}$	
Scanning System		Progressive	
Vertical Frequency (Frame Rate)		25 Hz at full resolution (12.5Hz on 10bit for ether net bandwidth limitation) 1.00000 to TBD Hz adjustable via the communication (Frame rate depends on the AOI setting) Maximum frame rate (TBD Hz) is when vertical resolution AOI setting is 32.	
Horizontal Frequency		54.4 kHz	
Pixel Frequency		120 MHz	
Noise Level	@ 8bit output	$\leq$ TBD Digit (Gain 0 dB)	
	@ 10bit output	$\leq$ TBD Digit (Gain 0 dB)	
Minimum Scene Illumination *Near IR (-NIR)		TBD Lux at F1.2, 25Hz	TBD Lux at F1.2, 25 Hz
		-	TBD Lux at F1.2, 25Hz
Sync. System		Internal	
Video Output Format		Digital 8, 10 bit Raw data or RGB 8 bit <b>(Default:8bit Raw)</b>	Digital 8, 10 bit Raw Data <b>(Default:8bit Raw)</b>
Interface		IEEE802.3 (1000BASE-T)	
Protocol		GigE Vision <sup>®</sup> 1.2 GenICam <sup>™</sup> 2.0	
Exposure Time		Preset continuous mode: 25 microseconds to 2000 milliseconds Preset trigger mode:25 microseconds to 2000 milliseconds Pulse width mode: 25 microseconds to 2000 milliseconds	
ALC (Automatic Light Control)		Automatic Exposure (AE) and Automatic Gain Control (AGC) (ON/OFF) (adjustable via the communication) <b>(Default: AE OFF, AGC ON)</b>	
Gain		x1 to x3 <b>(Default: x1)</b>	
Gamma		Gamma 1.0 (Factory default) or uploadable gamma table <b>(Default:1)</b>	
AOI Function		Variable AOI setting via the communication	
Color Interpolation		Available on RGB Output <b>(Default:ON)</b>	N/A
White Balance		Auto, Manual, Push to Set White Balance are available on both raw data and RGB outputs <b>(Default:OFF)</b>	N/A
Operational Mode		Edge preset trigger, Pulse width trigger <b>(Default:OFF)</b>	
Communication		UART communication through Ethernet port	
I/O		One opt-isolated input and two open collector outputs(+3.3V)	
Power	+10.8 to +26.4 Vdc	+10.8 to +26.4 Vdc	
	Less than TBD W	Less than TBD W	

## B. Spectral Sensitivity Characteristics

### 1. STC-CMB2MPOE / STC-CMB4MPOE

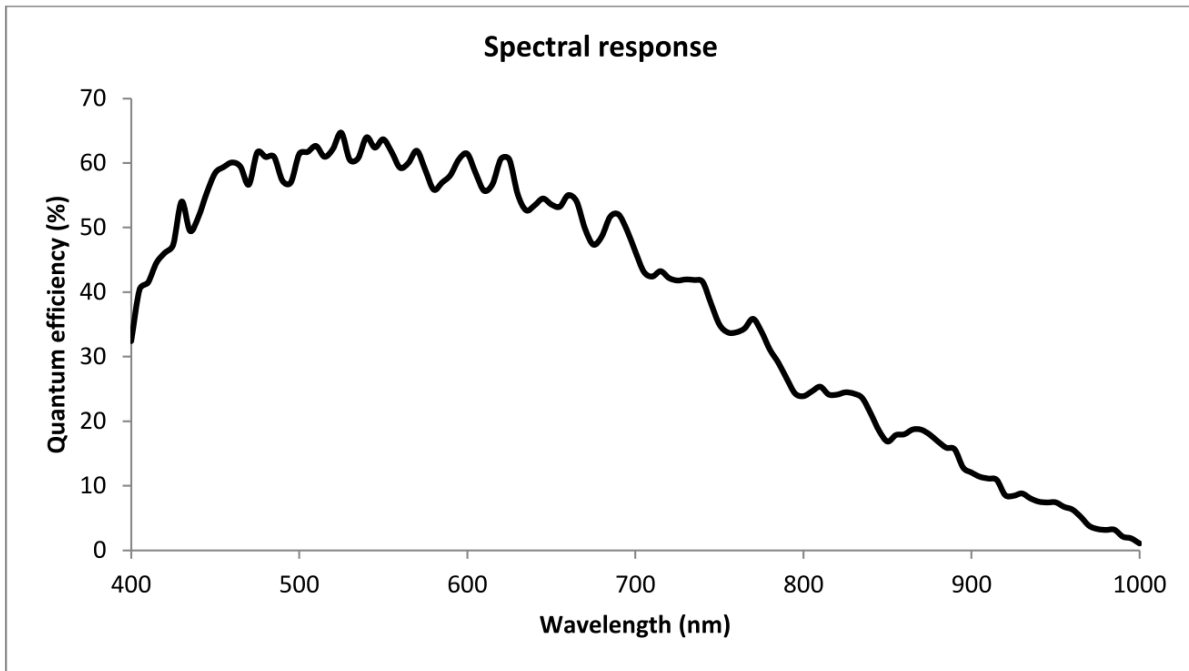

### 2. STC-CMC2MPOE / STC-CMC4MPOE

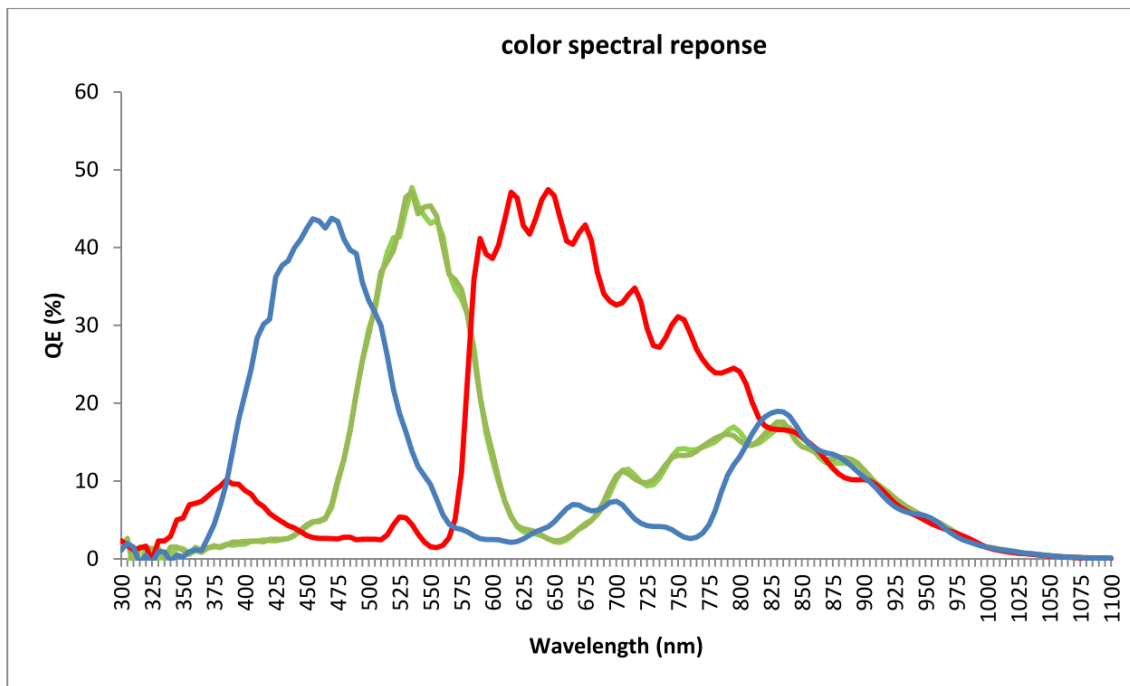



### 3. STC-CMB2MPOE-IR / CMB4MPOE-IR (Near IR Model)

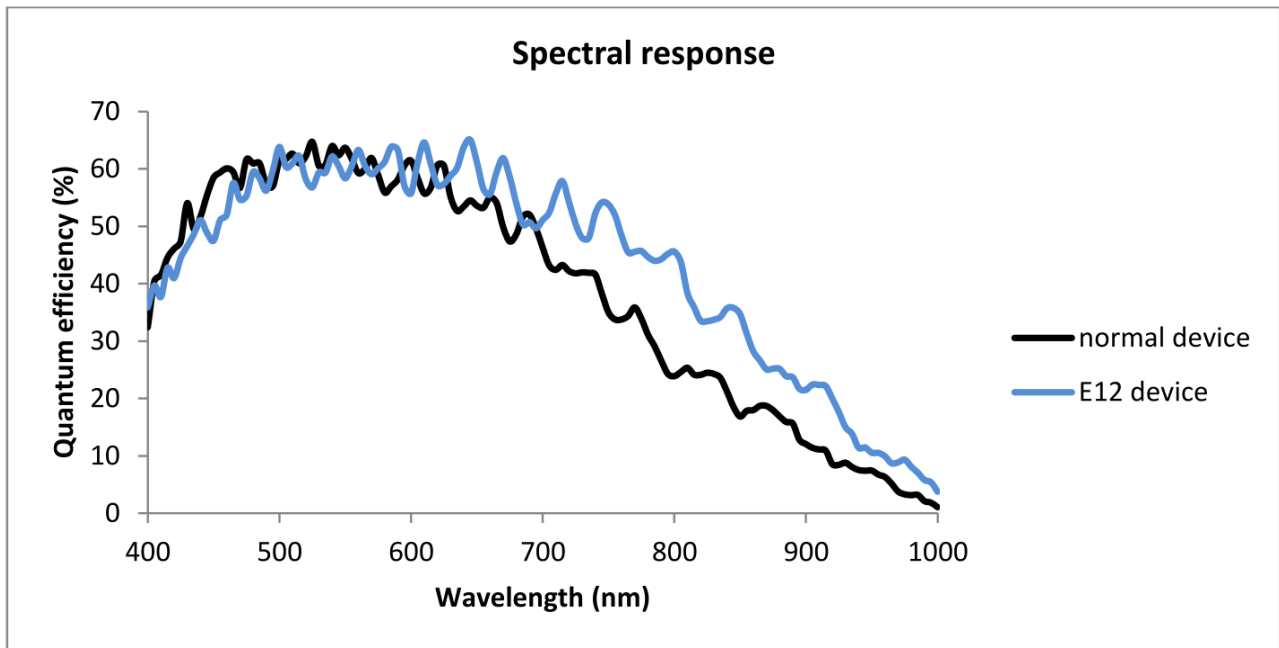

## C. Mechanical Specifications

Model Number	STC-CMC2MPOE, STC-CMC2MPOE, STC-CMC4MPOE, STC-CMB4MPOE
Dimensions	35 (W) x 35 (H) x 55.9(D) mm excluding connectors
Optical Filter	No Filter
Optical Center Accuracy	Positional accuracy in H and V directions: $\pm 0.3$ mm Rotational accuracy of H and V: $\pm 1.0$ deg
Material	Aluminum (AC)
Lens Mount	C mount
Connectors	RJ45 connector Power- I/O connector: HR10A-7R-6PB (Hirose) or equivalent
Camera Mount Screws	Two 1/4" Tripod screw holes: (One on each top and bottom plate), Twelve M4 screws holes: (Four on each top and bottom plate, two on each side plate)
Weight	TBD g

## D. Environmental Specifications

Model Number	STC-CMC2MPOE,STC-CMB2MPOE, STC-CMC4MPOE,STC-CMB4MPOE
Operational Temperature	Minimum Environmental Temperature $-5^{\circ}\text{C}$
	Maximum Camera housing temperature (top plate) shall not exceed $65^{\circ}\text{C}$ (This corresponds to an environmental temperature of approximately $35^{\circ}\text{C}$ )
Storage temperature	Environmental Temperature $-30^{\circ}\text{C}$ to $65^{\circ}\text{C}$
Vibration	20Hz to 200Hz to 20Hz (5min./cycle), acceleration 10G, 3 directions 30 min. each
Shock	Acceleration 38G, half amplitude 6ms, 3 directions 3 times each
Standard Compliancy	EMS: EN61000-6-2, EMI: EN55011
RoHS	RoHS Compliant

Note: When the camera is used in surrounding temperatures that exceed  $35^{\circ}\text{C}$ , please make sure that the camera is set up to properly radiate heat (maintaining the camera's top case plate's temperature to be less than  $65^{\circ}\text{C}$ ).

### III. Connector Specifications

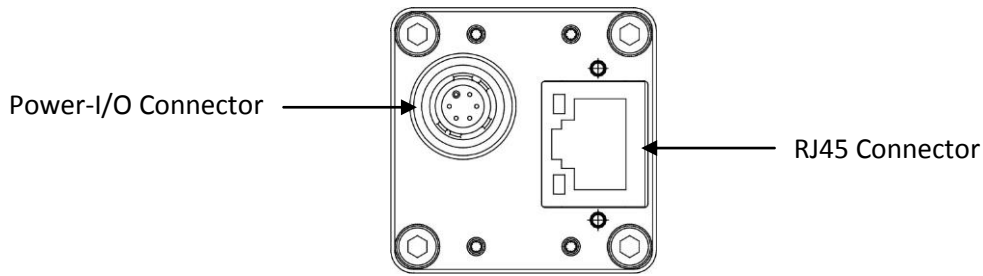

#### A. RJ45 Connector

**This product is PoE compliant. Please supply power (+10.8 to +26.4Vdc) through the power-I/O connector when using non-PoE-compliant NIC.**

Pin No.	Signal Name
1	TA+
2	TA-
3	TB+
4	TC+
5	TC-
6	TB-
7	TD+
8	TD-

Green LED	Yellow LED	Status
Green Light ON	Yellow Light ON	Power ON
Green Light ON	Yellow Light Blinking	1Gb Transferring
Light OFF	Yellow Light Blinking	100 Mb Transferring

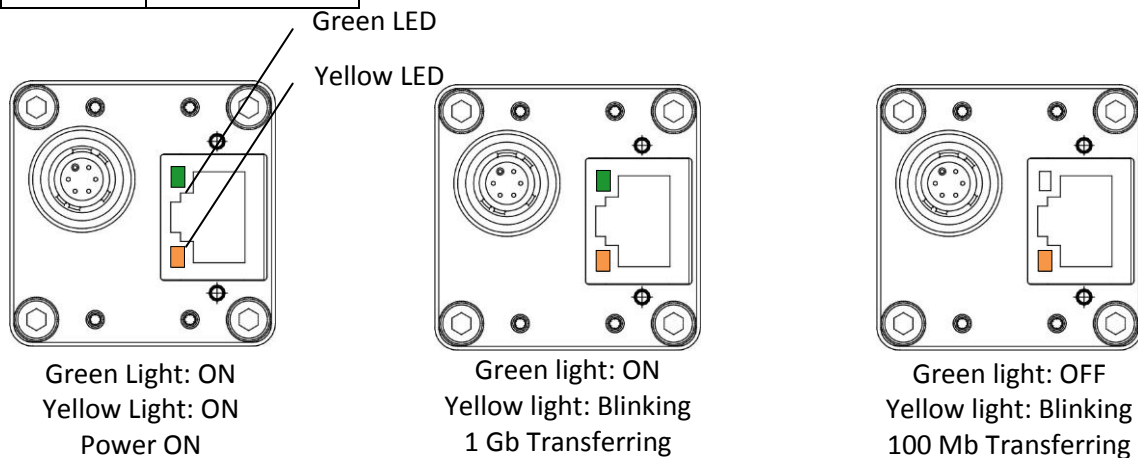

**Please use a Gigabit compatible network interface card (NIC) and/or network switch and LAN cable. In such a case, please also confirm that NIC and/or network switch is operating at Gigabit speeds.**

For the detail of Connection, please see "System Configurations (Example Connections)".

## B. Power-I/O Connector

- HR10A-7R-6PB (Hirose) or equivalent
- This connector is for the power supply (12Vdc) and input /output signals.
- Use HR10A-7P-6S (Hirose) or equivalent for the cable side.

Pin No.	Signal Name	IN / OUT	Voltage
1	GND	IN	0V
2	I/O-1	OUT	Open Collector
3	I/O-2	OUT	Open Collector
4	TRG_In- (Opt. Isolated -)	IN	Low: Smaller than +1.0V High: +3.0 to +26.4V
5	TRG_In+ (Opt. Isolated +)	IN	*potential difference between TRG_In- and TRG_In+
6	POWER IN	IN	+10.8 to +26.4 Vdc

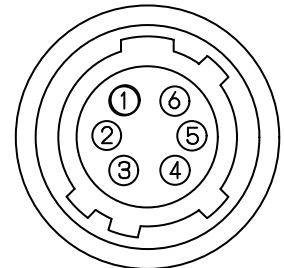

- Output signals can be assigned through the camera setting communication.  
(Device Code = 00H, Command = F0H and F1H)

Output pin can be assigned through register setting or GenICam Command.

Command No.				GenICam command
F0H[3..0]	F1[3]	F0H[7..4]	F1[4]	I/O-1 (Pin No.2) / I/O-2 (Pin No.3)
For I/O-1 (Pin No. 2)		For I/O-2 (Pin No.3)		
0H (initial setting)	-	0H	-	FrameTriggerWait (initial setting for I/O-1)
1H	Set Value	1H	Set Value	UserOutput
2H	-	2H (initial setting)		ExposureActive (initial setting for I/O-2)
3H	-	3H	-	TriggerAuxiliary
4H	-	4H		TriggerInternal
5H	-	5H		SensorReadOut
6H	-	6H		StrobeSignal
7H-FH	-	7H-FH	-	For Test Use Only

Note: I/O-1 can be assigned only by F0H[3..0] and F1[3], and I/O-2 can be assigned only by F0H[7..4] and F1[4].

## 1) FrameTriggerWait

The user can check the camera condition (camera exposure and image output processing by the trigger signal with this FrameTriggerWait signal).

This signal is LOW for the period from the trigger input signal to the image output.

The camera default setting is the input trigger signal is INVALID while at the low status of this signal. When the exposure starts while the image output by the next trigger signal, please change the camera setting (Device code: 00H, Command No. :13H) to accept the trigger signal while the image outputs.

The noise appears on the image when the start exposure while the image is output. In this case, please change the "H reset" for the exposure start mode (Device code: 00H, Command No. : 12H) to change the exposure start point to the next HD timing.

## 2) UserOutput

The status of the UserOutput signal can change with the "UserOutputValue".

## 3) ExposureActive

The user can check the exposure time with the ExposureActive signal.

## 4) TriggerAuxiliary

The TriggerAuxiliary signal is the input trigger signal.

## 5) TriggerInternal

The TriggerInternal signal is the input trigger signal with the trigger delay time.

## 6) SensorReadOut

The SensorReadOut signal is the FVAL signal, which is the image output period of the time.

## 7) StrobeSignal

The StrobeSignal signal is the strobe control signal.

## 1. Equivalent Circuit for the Input Pin of the I/O Connector

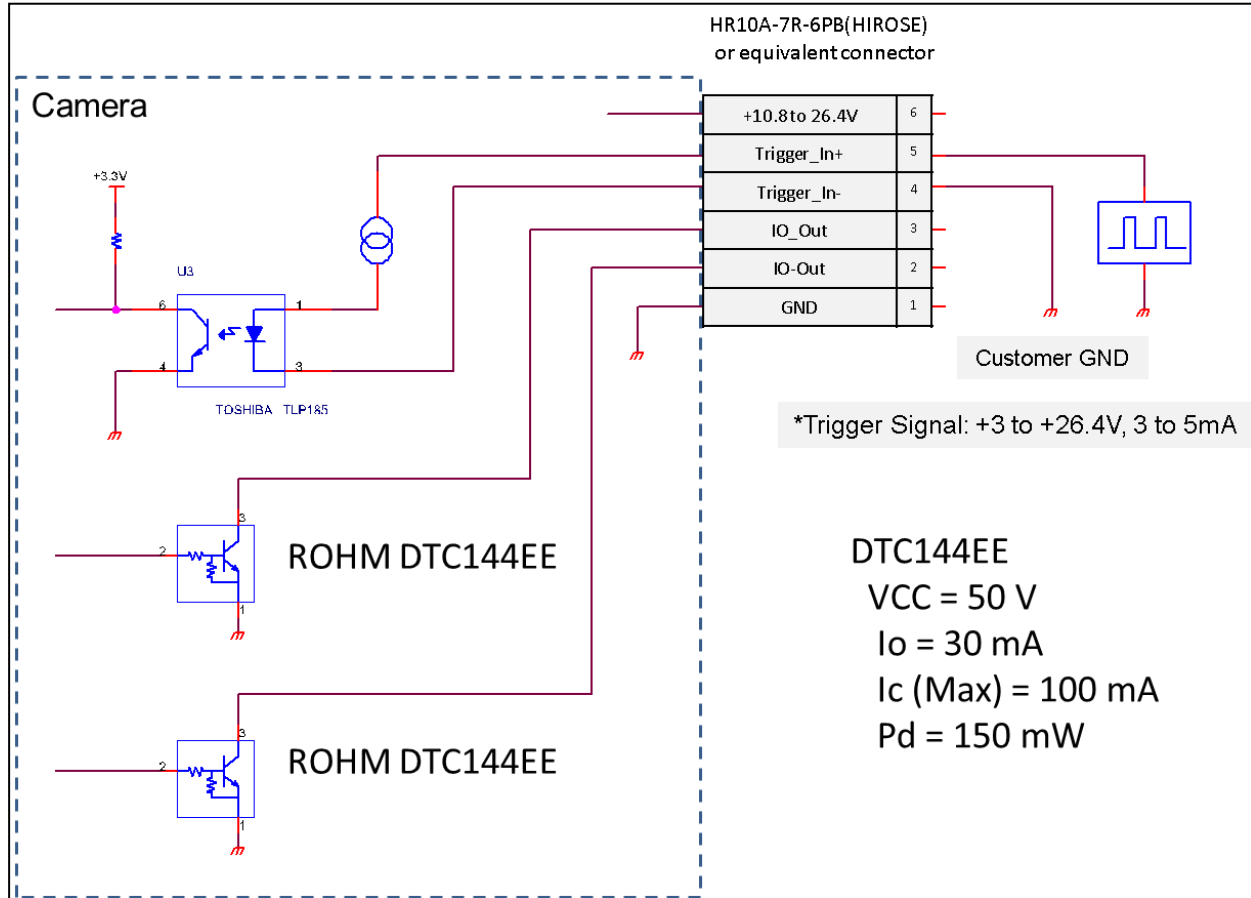

## 2. Typical Input Circuit

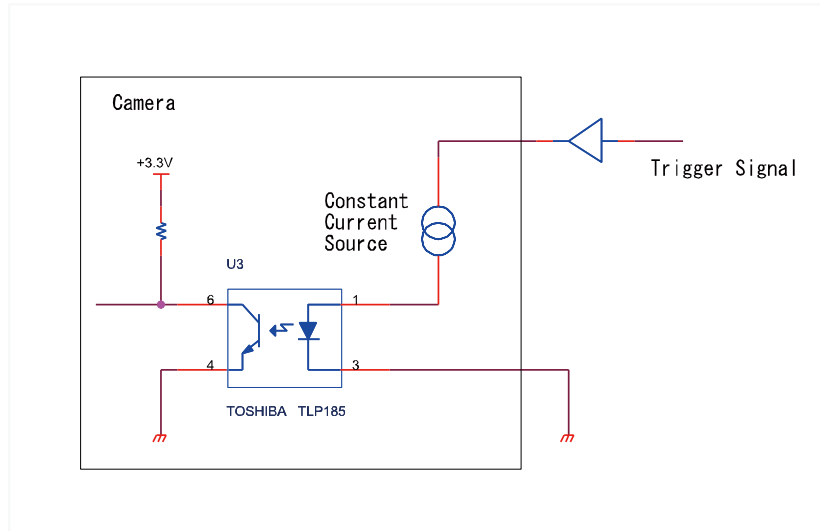

## 3. Typical Output Circuit

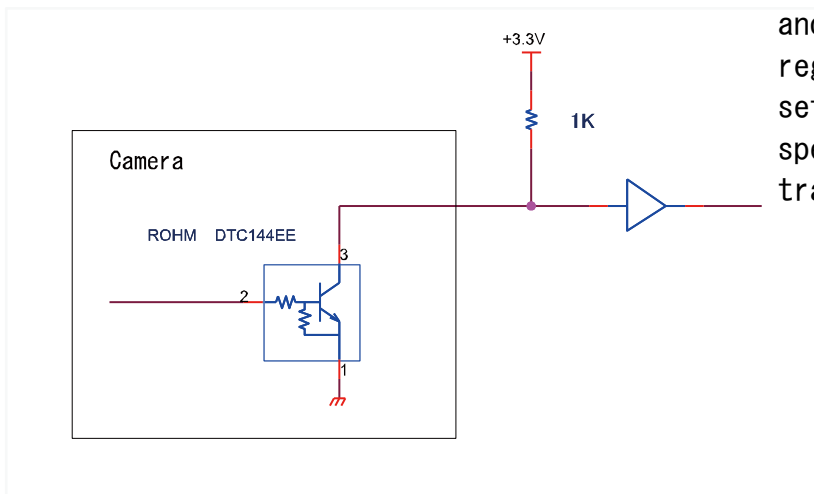

Note:  
Value of Vcc  
and Pull up  
register can be  
set within the  
spec of the  
transistor.



## IV. Dimensions

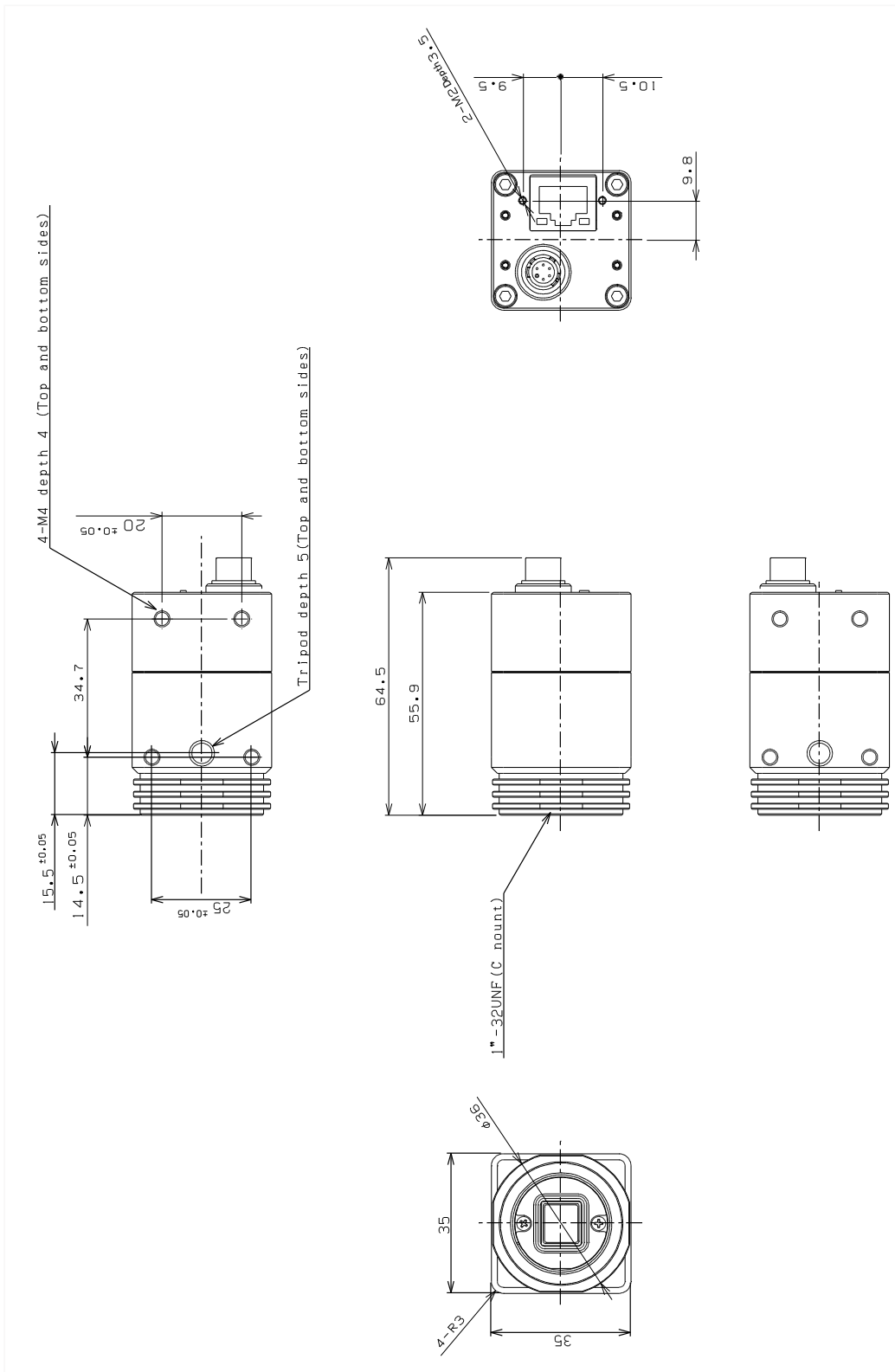

Unit: mm

Revisions

Rev	Date	Changes	Note
.02	September 19, 2013	Update Adjusted to a new model.	
.03	September 20, 2013	Update Dimensions Revised	

**Sensor Technologies America, Inc.**

1345 Valwood Pkwy, Suite 320  
Carrollton, Texas 75006-6891  
TEL (972) 481-9223 FAX (972) 481-9209  
URL <http://www.sentechamerica.com/>

**Sensor Technology Co., Ltd.**

7F, Harada Center Building  
9-17, Naka cho 4chrome  
Atsugi-city, Kanagawa  
243-0018 Japan  
TEL +81-46-295-7061 FAX +81-46-295-7066  
URL <http://www.sentech.co.jp/>

**Taiwan Sensor Technology, Inc.**

3F-6, No. 9, Aiguo W, Rd., Jhong Jheng District  
Taipei City 100, Taiwan, R.O.C.  
TEL 886-2-2383-2331 FAX 886-2-2370-8775  
EMAIL: sentech0501@yahoo.com.tw