



OUT OF THE BOX



The Samsung SNV-6013/FHM camera with Facit pre-installed App combines heat mapping with video surveillance

Heat Mapping – 360° view

Heat Mapping typical usage

includes visualising visitor traffic patterns and retail analysis of dwell time. Analyse customer behaviour and sales trends by understanding which products receive most interest.

Colour overlay

for identifying store hot spots of low or high activity / occupancy

Configuration & management

is designed to be operator friendly while the systems' reporting gives you a dashboard view of critical activity across your retail environments.

The Samsung SNV-6013/FHM camera

has been certified and tested by Facit.

Web based user interface

enables remote software set up & configuration.

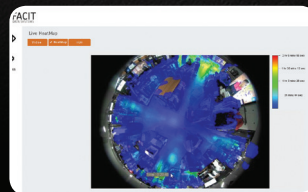

Network integration

allows real-time measurement over the network.

Automated reporting

can be set up daily.

Report delivery

by email or FTP.

Real time graphs

with hourly breakdown.

Quick Review

quickly and clearly review hotspots and areas of interest using the unique 'timelapse' review feature.

SNV-6013/FHM

2Megapixel Full HD Vandal-Resistant
Network Dome Camera

Key Features

- Max. 2M (1920 x 1080) resolution
- 0.15Lux@F1.8 (Color), 0.15Lux@F1.8 (B/W)
- Built-in 2.8 fixed lens
- WDR (120dB), DIS, Defog
- MD, FD, Video analytics
- SD/SDHC/SDXC memory slot
- PoE, IP66, IK10



SNV-6013/FHM	
CAMERA	
Report storage	over 12 months activity and reporting can be stored with an on-board micro SD card
Masking	specific sections of the camera view can be masked from heat map area including noise issues like light sources, escalators
Time measurement	Mouse placement on any part of heat map reveals exact time spent in that area
Key data	alongside the graph describes the colour coding pattern

Dimensions

Unit : mm (inch)

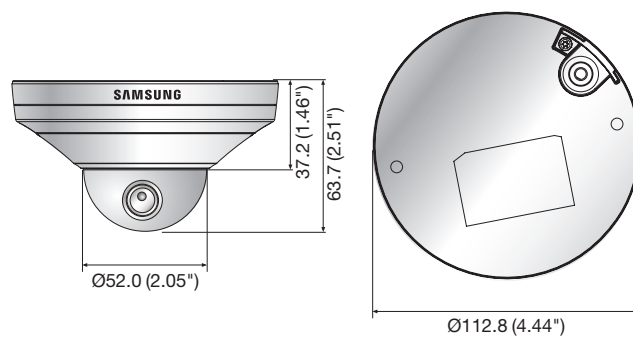

Accessories (Optional)



SBP-300HM7 SBP-300LM SBP-300CM SBP-300WM1 SBP-300WM SBP-300B SBP-300PM SBP-300KM

■ DISTRIBUTED BY



HANWHA TECHWIN EUROPE LTD.

2nd Floor, No. 5 The Heights, Brooklands, Weybridge, Surrey, KT13 0NY, UK
Tel : +44-1932-82-6700 Fax: +44 1932 82 6701 www.samsung-security.eu
COPYRIGHT BY HANWHA TECHWIN. ALL RIGHTS RESERVED

SAMSUNG