

VIDEOJET connect 7000

www.boschsecurity.com



BOSCH
Invented for life



- ▶ Operates a variety of Bosch HD PTZ cameras, including MIC7000
- ▶ Alarms, washer pump control, local storage slot for a CompactFlash (CF) memory card, built-in web browser for control of connected cameras
- ▶ One (1) HD-BaseT PoH dedicated for one RJ45 Ethernet port; three (3) RJ45 ports; two (2) SFP ports
- ▶ Support for daisy-chaining of multiple cameras

The device VIDEOJET connect 7000 (VJC-7000-90) is a full-featured network power supply unit that can operate a variety of Bosch PTZ cameras such as MIC7000. The device includes one (1) HPoE network connection, two (2) standard network interfaces for connections to additional IP devices, one (1) slot for an optional CompactFlash (CF) memory card, two (2) slots for use with SFP-based fiber optic modules, alarm/washer control interfaces*, and audio in.

* **Note:** This feature is valid only for a MIC7000 camera "bound" to Camera 1.

System overview

Note: To achieve a distance of 100 m (328 ft) using Cat5e/Cat6e cable, Bosch recommends using cable with a minimum rating of 350 MHz.

Certifications and approvals

Electromagnetic Compatibility (EMC)	Complies with FCC Part 15 Class A, ICES-003, and CE regulations, including latest versions of EN 50130-4, EN 55022:2010, EN 61000-3-3, EN 61000-6-1, and EN 61000-6-2
-------------------------------------	---

Product Safety	Complies with UL, CE, CSA, EN, and IEC Standards 60950-1 & 22
Ingress Protection Rating/Standard	IP66, IP67, NEMA Type 4

Installation/configuration notes

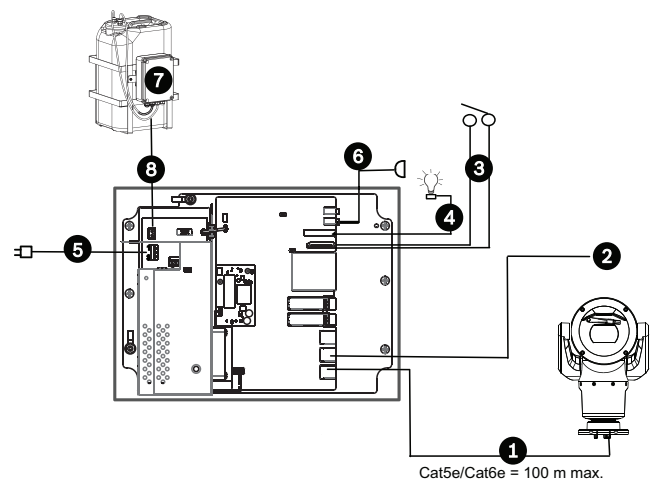

Basic configuration with VIDEOJET connect 7000

- 1 Ethernet (network) cable (Cat5e/Cat6e) (user-supplied) between a Bosch camera and the port labeled *PoE* on VIDEOJET connect 7000
- 2 Data-only IP cable (Cat5e/Cat6e) to the head-end network
Note: The cable to the head-end also can be fiber optic cable from one of the two SFP slots.
- 3 Alarm input / output interface cables (user-supplied)
- 4 Alarm output cables (user-supplied)
- 5 120 / 230 VAC, 50/60 Hz
- 6 Audio input interface cable (user-supplied)
- 7 External washer pump (user-supplied)
- 8 Washer output, 2-conductor (user-supplied)

Parts included

- One (1) VIDEOJET connect 7000 enclosure with three (3) M16 plugs, three (3) ¼" blanking plugs, and five (5) M16 gland locknuts installed
- Parts bag with:
 - one (1) terminal plug connector, 2-pin [for connections to optional washer]
 - one (1) terminal plug connector, 3-pin [for AC mains power input]
 - one (1) terminal plug connector, 6-pin [for alarm inputs]
 - one (1) terminal plug connector, 7-pin [for alarm outputs and for the supervised alarm input]
 - three (3) watertight M16 cable glands with O-rings
- Installation Manual

Technical specifications

Electrical

Power requirements	100 VAC - 240 VAC (90 VAC - 264 VAC with tolerance considered), 50/60 Hz, 1.6 A max.
Input power	184 W
HPoE output	95 W / 56V

Network

Communication	3x 10BASE-T/100BASE-TX/1000Base-TX If SFP fiber optic modules installed: 2x 1000 BASE-FX
---------------	---

SFP Modules

SFP (small form-factor pluggable) slot	Two (2) for use with SFP-based fiber optic modules (1GB only) such as: <ul style="list-style-type: none"> • Agilent, SFP-GE-SX-MM850-A HFBR5710LP 7 • Cisco, GLC-LH-SM 1300nm • Cisco, GLC-SX-MM 850nm 8 • Finisar, FTLF8519P2BTL 850nm
--	---

Audio

Audio IN	
- Standard	G.711, 8 kHz sampling rate L16, 16 kHz sampling rate AAC, 16 kHz sampling rate
- Signal-to-Noise Ratio (SNR)	>50 dB

Storage

Local storage	One (1) slot for optional CompactFlash (CF) memory card, Type I / Type II, True IDE Mode, 1 TB max (user-supplied)
---------------	--

Miscellaneous

Washer switch	Push button to activate/test the washer relay momentarily
---------------	---



Notice

A MIC7000 camera connected to VIDEOJET connect 7000 requires firmware version 5.93 or later. Download the firmware from <https://downloadstore.boschsecurity.com>.

User Connections

Alarm Inputs	Four (4) normal dry contacts (selectable N.O./N.C.) Monitored supervised alarm input (Alarm 1), 2.2K ohm (Ω) end-of-line terminating resistor
Alarm Outputs	Three (3) open collector outputs, 32 VDC, 150 mA
Washer driver output	Dry contact relay, 250 V, 5 A
RJ45 connectors	(3) – one PoE/PoH, 95W max; two standard network connections suitable for interface to head end network and 'daisy chain' type connection to second camera or VJC-7000-90 location

Audio	
- Connector	3.5 mm stereo jack
- Signal line in	9 kohm typical, 5.5 Vpp max.

Environmental

Ingress Protection Rating/Standard	IP66, IP67, NEMA Type 4
Operating Temperature	-40 °C to +60 °C (-40 °F to +140 °F)
Storage Temperature	-60 °C to +70 °C (-76 °F to +158 °F)
Humidity	0–100%

Construction

Dimensions (L x W x H)	330 mm x 250 mm x 90.75 mm (13 in. x 9.84 in. x 3.57 in.)
Weight	7.21 kg (15.9 lb)
Material	Powder-coated cast aluminum
Color	White (RAL 9010) with sand finish
Standard Finish	Powder coat paint, sand finish
Glands	Water-tight glands/seals, rated IP67, NEMA Type 4

Dimensional Drawings

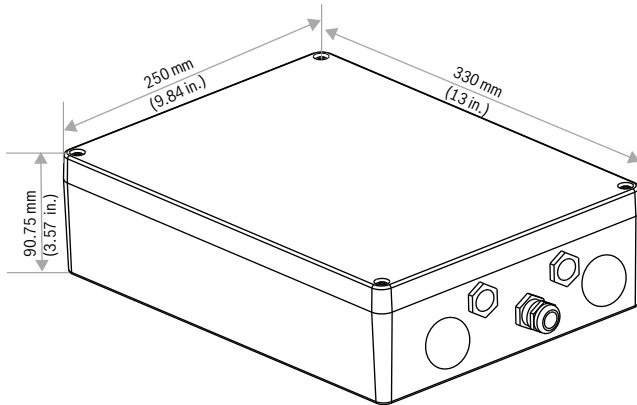

Ordering information

VIDEOJET connect 7000

95 W, PoE IP power supply unit, 100 VAC - 240 VAC
(90 VAC - 264 VAC with tolerance considered), 50/60
Hz

Order number **VJC-7000-90**

Represented by:

North America:
Bosch Security Systems, Inc.
130 Perinton Parkway
Fairport, New York, 14450, USA
Phone: +1 800 289 0096
Fax: +1 585 223 9180
security.sales@us.bosch.com
www.boschsecurity.us

Europe, Middle East, Africa:
Bosch Security Systems B.V.
P.O. Box 80002
5617 BA Eindhoven, The Netherlands
Phone: + 31 40 2577 284
Fax: +31 40 2577 330
emea.securitysystems@bosch.com
www.boschsecurity.com

Asia-Pacific:
Robert Bosch (SEA) Pte Ltd, Security
Systems
11 Bishan Street 21
Singapore 573943
Phone: +65 6571 2808
Fax: +65 6571 2699
apr.securitysystems@bosch.com
www.boschsecurity.asia

China:
Bosch (Shanghai) Security Systems Ltd.
203 Building, No. 333 Fuquan Road
North IBP
Changning District, Shanghai
200335 China
Phone +86 21 22181111
Fax: +86 21 22182398
www.boschsecurity.com.cn

Latin America and Caribbean:
Robert Bosch Ltda Security Systems Division
Via Anhanguera, Km 98
CEP 13065-900
Campinas, Sao Paulo, Brazil
Phone: +55 19 2103 2860
Fax: +55 19 2103 2862
latam.boschsecurity@bosch.com
www.boschsecurity.com