

NITEK®

TT560

Active Transmitter Unit for UTP Transmission
from 500 to 6,000 feet (152 to 1,828 meters)

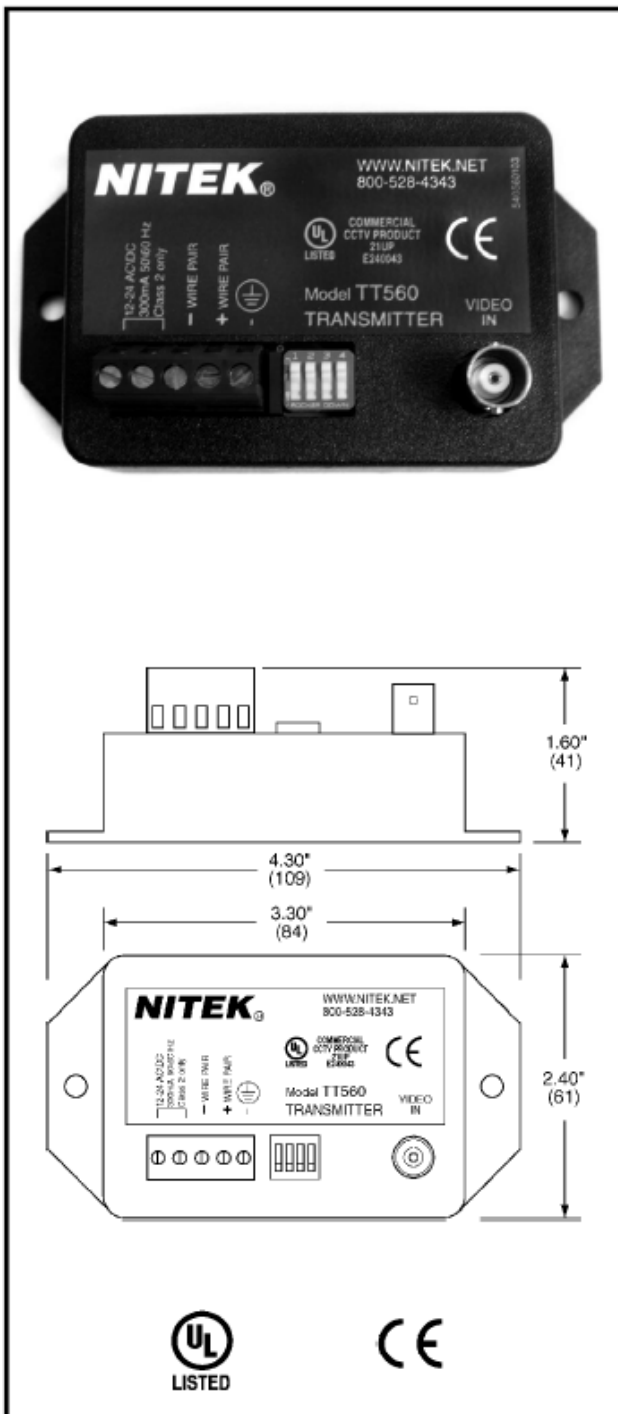

Description

Live video transmission for operation over twisted pair or Category 5 cables up to 6,000 feet (1,828 meters).

The TT560 is designed for operation over Category 2, 3, 4 or 5 twisted pair cable and requires a Nitek active receiver unit. The units work equally well over existing communication and computer network spare pairs, or new cable installations. A highly balanced transmitter output design assures that the system will not interfere with other equipment on the network. In addition, the transmitter is virtually impervious to ground loop and has high immunity to noise and interference from other signals. Built-in surge suppression is standard.

A dip switch on the unit provides precise adjustment of gain and frequency compensation, allowing the system to be "fine-tuned" for any cable.

The TT560 includes the transmitter and a power supply for the receiver. Complete systems including the receiver, transmitter and power supplies are available. For more information refer to the Ordering Information section of this sheet or call Nitek.

Features

- Active electronics compensate for frequency and level loss
- Built-in protection from power surge, transients, static or other electrical interference
- High resolution color or monochrome video
- Complete immunity to ground loop; video and AC can be run in a common raceway, where allowed
- Video can be run in the same cable with telephone and computer signals
- Weather resistant design
- Easy to install

Applications

College Campuses - using existing communication cables saves time and money

High Rise Buildings - between floors, through punch-down blocks

Detention Facilities - twisted pair takes less space than coax in a conduit

High Voltage Facilities - high immunity to AC power interference

Parking Garages - where running coax is difficult to impossible

Remote Gates - can be run in same cable with audio and gate control

Transmitter Unit

Size	1.6"H x 4.3"W x 2.4"D
Power Requirements	12-24 VAC or VDC@45mA (wall transformer provided with unit)
Output	Balanced low voltage current loop
Input	1 Vpp composite video Monochrome or Color
Common Mode Rejection	>70dB (with TR560 receiver)
Video Format	RS170, NTSC, PAL, SECAM, CCIR (Color or B/W)
Operating Frequency	DC to 10 MHz
Recommended Transmission Distance	up to 6,000 feet (1,828 meters) for both monochrome and color
Wire Size	26 to 12 AWG unshielded twisted pair
UTP Category	Unshielded Category 2 or better
Temperature Range	-40 degrees C to +85 degrees C
Humidity Range	0 to 98%, non-condensing
Enclosure Material	Black ABS flame retardant plastic
Twisted Pair Connection	Screw terminals

Ordering Information		
PART	RANGE	SYSTEM INCLUDES
TT560	100 to 1,500 feet (30 to 457 meters)	Transmitter & Power Pack
TR560	100 to 6,000 feet (30 to 1,828 meters)	Receiver & Power Pack
EX560	500 to 6,000 feet (152 to 1,828 meters)	TT560, TR560 & (2) Power Packs
TR560x4	500 to 6,000 feet (152 to 1,828 meters)	Receiver Card for Modular Systems
EX560x4	500 to 6,000 feet (152 to 1,828 meters)	(4) TT560, TR560x4 & (4) Power Packs

SYSTEM COMPONENTS

For more information on individual components listed above refer to respective specification sheets.

Wire and Cable Recommendations

Twisted Sender is recommended for use with **unshielded twisted pair** (UTP) wiring. The systems will operate over wire gauges from 26 AWG through 12 AWG but are optimized for 24 AWG. Category 2, 3, 4 or 5 cable may be used. Individually shielded pairs should be avoided as they drastically reduce the operating range of the systems. Multi-pair cable with an overall shield is acceptable. Video can be operated in the same communication cable coexistent with telephone, computer, control signals, power voltages and other video signals. While video may be routed through telephone punchdown block terminals, any bridge-taps, also called T-taps and any resistive, capacitive or inductive devices **MUST BE** removed from the pair. For more specific information regarding wire types, gauges and proper installation techniques, please call 800-528-4343 for technical assistance. More information is also available on the CCTV System Design Guide Sheet.

